

TECHNICAL MANUAL

OPERATOR'S, UNIT, INTERMEDIATE DIRECT SUPPORT, AND GENERAL SUPPORT MAINTENANCE MANUAL

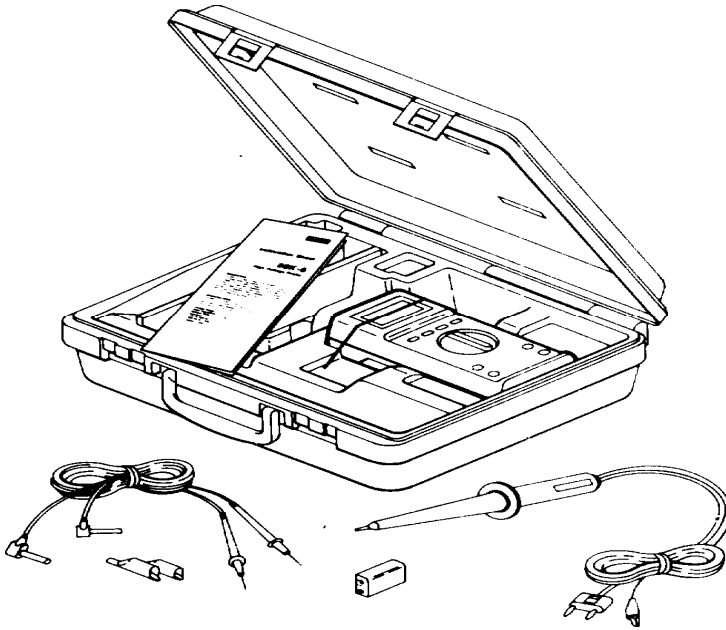

DIGITAL MULTIMETER AN/PSM-45A

(NSN 6625-01-265-6000) (EIC: N/A)

WARNING – This document contains technical data whose export is restricted by the Arms Export Control Act (Title 22, U. S. C., Sec 2751 et seq) or the Export Administration Act of 1979, as amended, Title 50, U.S.C., App. 2401 et seq.. Violations of these export laws are subject to severe criminal penalties. Disseminate in accordance with provisions of DOD Directive 5230.25.

DISTRIBUTION STATEMENT D – Distribution authorized to Department of Defense and DoD contractors only to protect critical technical data on systems or hardware. This determination was made Oct 1986. Other requests shall be referred to: Program Manager, TMDE, ATTN: SFAE-CS-FT-T-TEMOD, Redstone Arsenal, AL 35898-5000.

DESTRUCTION NOTICE – Destroy by any method that will prevent disclosure of contents or reconstruction of the document.

**EQUIPMENT
DESCRIPTION
PAGE 1-2**

**OPERATOR'S
CONTROLS
PAGE 2-1**

**OPERATION
PAGE 2-4**

**UNIT
TROUBLESHOOTING
PAGE 3-2**

**UNIT MAINTENANCE
PROCEDURES
PAGE 3-3**

**GENERAL SUPPORT
TROUBLESHOOTING
PAGE 5-1**

**GENERAL SUPPORT
MAINTENANCE
PROCEDURES
PAGE 5-1**

**SUBJECT
INDEX
PAGE INDEX-1**

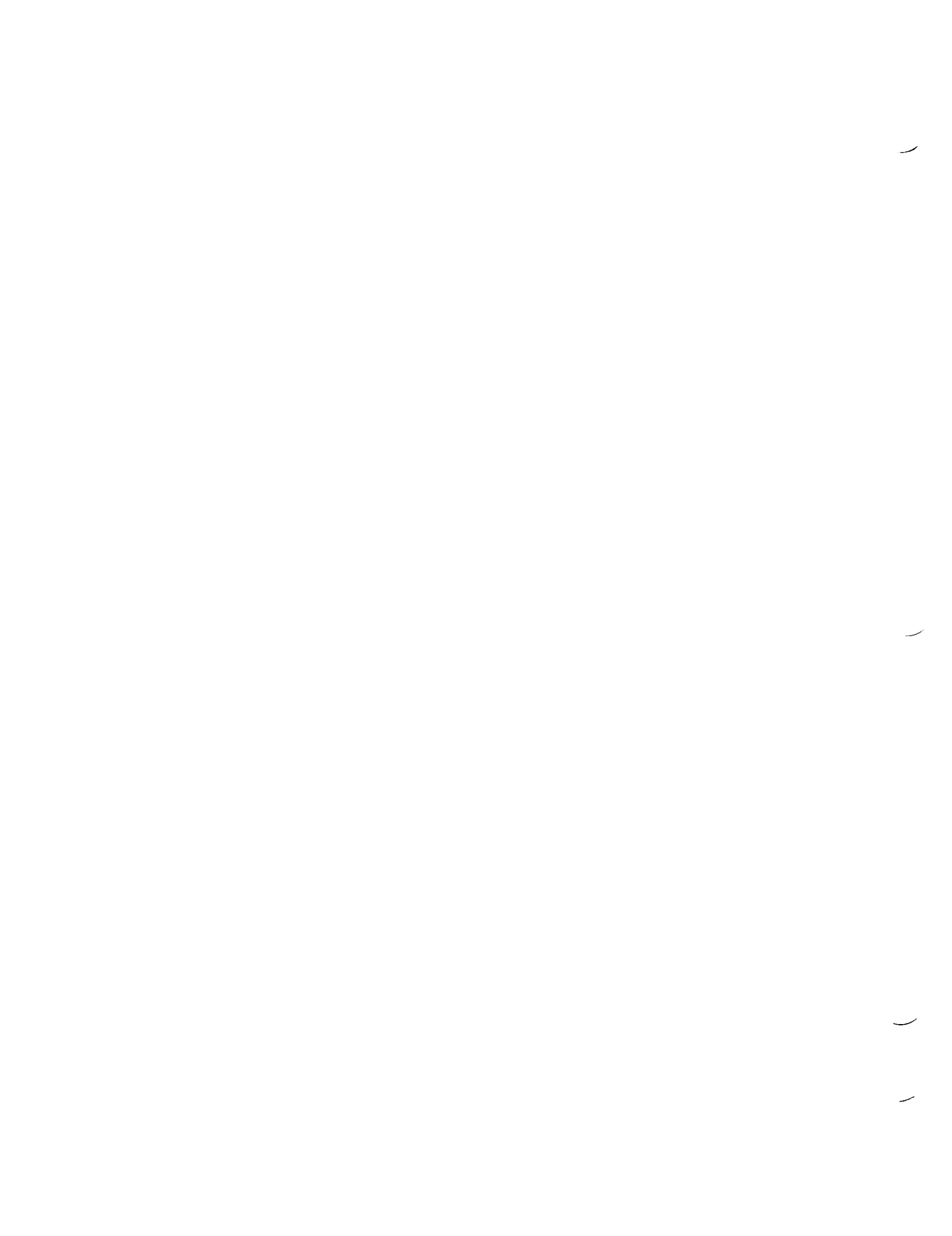



5

SAFETY STEPS TO FOLLOW IF SOMEONE IS THE VICTIM OF ELECTRICAL SHOCK:

1

DO NOT TRY TO PULL OR GRAB THE INDIVIDUAL.

2

IF POSSIBLE, TURN OFF THE ELECTRICAL POWER.

3

IF YOU CANNOT TURN OFF THE ELECTRICAL POWER, PULL, PUSH, OR LIFT THE PERSON TO SAFETY USING A DRY WOODEN POLE OR A DRY ROPE OR SOME OTHER INSULATING MATERIAL.

4

SEND FOR HELP AS SOON AS POSSIBLE.

5

AFTER THE INJURED PERSON IS FREE OF CONTACT WITH THE SOURCE OF ELECTRICAL SHOCK, MOVE THE PERSON A SHORT DISTANCE AWAY AND IMMEDIATELY START ARTIFICIAL RESUSCITATION.

WARNING

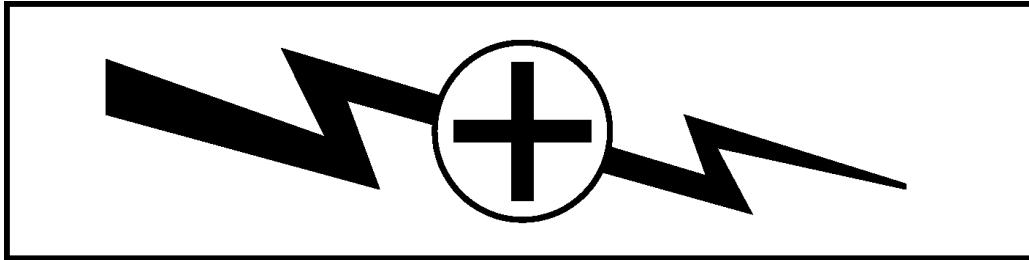

HIGH VOLTAGE

is used in the operation of this equipment.

DEATH ON CONTACT

may result if personnel fail to observe safety precautions.

Never work on electronic equipment unless there is another person nearby who is familiar with the operation and hazards of the equipment and who is competent in administering first aid. When technicians are aided by operators, they must warn them about dangerous areas.

Whenever possible, the power supply to the equipment must be shut off before beginning work on the equipment. Take particular care to ground every capacitor likely to hold a dangerous potential. When working inside the equipment, after the power has been turned off, always ground every part before touching it.

Be careful not to contact high-voltage connections of 115-volt ac input when installing or operating this equipment.

Whenever the nature of the operation permits, keep one hand away from the equipment to reduce the hazard of current flowing through vital organs of the body.

WARNING

Do not be misled by the term "LOW VOLTAGE." Potentials as low as 50 volts can cause death under certain conditions.

For First Aid, refer to FM 4-25.11.

b Change 2

CHANGE }
No. 2 }

Headquarters
Department of the Army
Washington, D.C., 27 April 2007

**OPERATOR'S, UNIT, INTERMEDIATE DIRECT SUPPORT,
AND GENERAL SUPPORT MAINTENANCE MANUAL
FOR
DIGITAL MULTIMETER
AN/PSM-45A
(NSN 6625-01-265-6000) (EIC: N/A)**

HAZARDOUS MATERIAL INFORMATION – This document has been reviewed for the presence of solvents containing hazardous materials as defined by the EPCRA 302 and 313 lists by the Engineering, Environment, and Logistics Oversight Office. As of the base document through Change 1, dated 15 June 1990, all references to solvents containing hazardous materials have been removed from this document by substitution with non-hazardous or less-hazardous materials where possible.

OZONE DEPLETING CHEMICAL INFORMATION – This document has been reviewed for the presence of Class I ozone depleting chemicals by the Engineering, Environment, and Logistics Oversight Office. As of the base document through Change 1, dated 15 June 1990, all references to Class I ozone depleting chemicals have been removed from this document by substitution with chemicals that do not cause atmospheric ozone depletion.

WARNING – This document contains technical data whose export is restricted by the Arms Export Control Act (Title 22, U. S. C., Sec 2751 et seq) or the Export Administration Act of 1979, as amended, Title 50, U.S.C., App. 2401 et seq.. Violations of these export laws are subject to severe criminal penalties. Disseminate in accordance with provisions of DOD Directive 5230.25.

DISTRIBUTION STATEMENT D – Distribution authorized to Department of Defense and DoD contractors only to protect critical technical data on systems or hardware. This determination was made Oct 1986. Other requests shall be referred to: Program Manager, TMDE, ATTN: SFAE-CS-FT-T-TEMOD, Redstone Arsenal, AL 35898-5000.

DESTRUCTION NOTICE – Destroy by any method that will prevent disclosure of contents or reconstruction of the document.

TM 11-6625-3199-14, dated 15 December 1988, is changed as follows:

1. Remove old pages and insert new pages as indicated below. New or changed material is indicated by a vertical bar in the outer margin of the page.

Remove Pages

A and B
None
i and ii
iii and 1-0
1-1 and 1-2
3-1 and 3-2
A-1/(A-2 blank)

Insert Pages

a and b
A/(B blank)
i and ii
iii and 1-0
1-1 and 1-2
3-1 and 3-2
A-1/(A-2 blank)

TM 11-6625-3199-14
C2

Remove Pages

B-1 through B-6
C-1 and C-2
D-1/(D-2 blank)
E-1/(E-2 blank)
DA Forms 2028-2
Cover

Insert Pages

B-1 through B-5/(B-6 blank)
C-1 and C-2
D-1/(D-2 blank)
E-1/(E-2 blank)
DA Forms 2028
Cover

2. File this change sheet in front of the publication for reference purposes.

By Order of the Secretary of the Army:

Official:

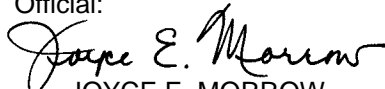
JOYCE E. MORROW
*Administrative Assistant to the
Secretary of the Army*
0705207

GEORGE W. CASEY, JR.
*General, United States Army
Chief of Staff*

Distribution:

To be distributed in accordance with the initial distribution number (IDN) 367948, requirements for TM 11-6625-3199-14.

Change
No. 1

HEADQUARTERS
DEPARTMENT OF THE ARMY,
Washington, DC, 15 June 1990

OPERATORS, UNIT, DIRECT SUPPORT AND GENERAL
SUPPORT MAINTENANCE MANUAL
FOR
DIGITAL MULTIMETER, AN/PSM-45A
(NSN 6625-01-265-6000)

TM 11-6625-3199-14, 15 December 1986, is changed as follows:

1. Title of manual is changed as shown above.
2. Remove old pages and insert new pages as indicated below. New or changed material is indicated by a vertical bar in the margin of the page. Added or revised illustrations are indicated by a vertical bar adjacent to the identification number or by a pointing hand on the illustration page.

Remove pages

Insert pages

5-1/(5-2 Blank)	5-1/(5-2 Blank)
B-3 through B-6	B-3 through B-6

2. File this change in the front of the publication for reference purposes.

Distribution authorized to the Department of Defense and DOD contractors only for official use or for administrative or operational purposes. This determination was made on 5 July 1988. Other requests for this document will be referred to Commander, US Army Communications-Electronics Command Fort Monmouth, ATTN: AMSEL-LC-ME-P, Fort Monmouth, NJ 07703-5000.

DESTRUCTION NOTICE - Destroy by any method that will prevent disclosure of contents or reconstruction of the document.

By Order of the Secretary of the Army:

CARL E. VUONO
General, United States Army
Chief of Staff

Official:

WILLIAM J. MEEHAN II
Brigadier General, United States Army
The Adjutant General

Distribution:

To be distributed in accordance with special list.

INSERT LATEST CHANGED PAGES. DESTROY SUPERSEDED PAGES.

LIST OF EFFECTIVE PAGES

NOTE

ON CHANGED PAGES, THE PORTION OF THE TEXT AFFECTED BY THE LATEST CHANGE IS INDICATED BY A VERTICAL LINE OR OTHER CHANGE SYMBOL IN THE OUTER MARGIN OF THE PAGE.

Date of issue for original and changed pages are:

Original	0	15 December 1988
Change	1	15 June 1990
Change	2	27 April 2007

Total number of pages in this publication is 89 consisting of the following:

Page No.	* Change No.	Page No.	*Change No.
Cover.....	2	4-2 blank.....	0
a and b	2	5-1	2
A	2	5-2 blank.....	2
B blank	2	A-1	2
i and ii	2	A-2 blank	2
iii	2	B-1 through B-5	0
1-0	0	B-6 blank	2
1-1 and 1-2	2	C-1	0
1-3 through 1-7.....	0	C-2.....	2
1-8 blank	0	D-1	0
2-1 through 2-24.....	0	D-2 blank	0
3-1	2	E-1	2
3-2	0	E-2 blank	2
3-3 through 3-9.....	0	Index-1 through Index-4	0
3-10 blank	0		
4-1	0		

TECHNICAL MANUAL
NO. 11-6625-3199-14

HEADQUARTERS
DEPARTMENT OF THE ARMY
WASHINGTON, D.C., 15 DECEMBER 1988

**OPERATOR'S, UNIT, INTERMEDIATE DIRECT SUPPORT, AND GENERAL
SUPPORT MAINTENANCE MANUAL
FOR
DIGITAL MULTIMETER
AN/PSM-45A
(NSN 6625-01-265-6000) (EIC: N/A)**

REPORTING ERRORS AND RECOMMENDING IMPROVEMENTS

You can help improve this manual. If you find any mistakes or if you know of a way to improve the procedures, please let us know. Mail your letter or DA Form 2028 (Recommended Changes to Publications and Blank Forms) directly to: Commander, U. S. Army Aviation and Missile Command, AMSAM-MMC-MA-NP, Redstone Arsenal, AL 35898-5000. A reply will be furnished to you. You may also provide DA Form 2028 information to AMCOM via email, fax or the World Wide Web. Our fax number is: DSN 788-6546 or Commercial 256-842-6546. Our email address is: 2028@redstone.army.mil. Instructions for sending an electronic 2028 may be found at the back of this manual immediately preceding the hardcopy 2028. For the World Wide Web use: <https://amcom2028.redstone.army.mil>.

HAZARDOUS MATERIAL INFORMATION

This document has been reviewed for the presence of solvents containing hazardous materials as defined by the EPCRA 302 and 313 lists by the Engineering, Environment, and Logistics Oversight Office. As of the base document, through Change 1 dated 15 June 1990, all references to solvents containing hazardous materials have been removed from this document by substitution with non-hazardous or less hazardous materials where possible.

OZONE DEPLETING CHEMICAL INFORMATION

This document has been reviewed for the presence of Class I ozone depleting chemicals by the Engineering, Environment, and Logistics Oversight Office. As of the base document, through Change 1 dated 15 June 1990, all references to Class I ozone depleting chemicals have been removed from this document by substitution with chemicals that do not cause atmospheric ozone depletion.

WARNING – This document contains technical data whose export is restricted by the Arms Export Control Act (Title 22, U. S. C., Sec 2751 et seq) or the Export Administration Act of 1979, as amended, Title 50, U.S.C., App. 2401 et seq.. Violations of these export laws are subject to severe criminal penalties. Disseminate in accordance with provisions of DOD Directive 5230.25.

DISTRIBUTION STATEMENT D – Distribution authorized to Department of Defense and DoD contractors only to protect critical technical data on systems or hardware. This determination was made Oct 1986. Other requests shall be referred to: Program Manager, TMDE, ATTN: SFAE-CS-FT-T-TEMOD, Redstone Arsenal, AL 35898-5000.

DESTRUCTION NOTICE – Destroy by any method that will prevent disclosure of contents or reconstruction of the document.

TABLE OF CONTENTS

		Page
HOW TO USE THIS MANUAL		iii
CHAPTER 1	INTRODUCTION	1-1
Section I	General Information.....	1-1
Section II	Equipment Description	1-2
Section III	Technical Principles of Operation.....	1-6
CHAPTER 2	OPERATING INSTRUCTIONS	2-1
Section I	Description and Use of Operator's Controls, Indicators and Connectors	2-1
Section II	Operation Under Usual Conditions	2-4
Section III	Operation Under Unusual Conditions.....	2-24
CHAPTER 3	UNIT MAINTENANCE.....	3-1
Section I	Repair Parts, Special Tools, TMDE, and Support Equipment.....	3-1
Section II	Service Upon Receipt.....	3-1
Section III	Troubleshooting.....	3-2
Section IV	Maintenance Procedures.....	3-3
Section V	Preparation for Storage or Shipment.....	3-9
CHAPTER 4	DIRECT SUPPORT MAINTENANCE	4-1
CHAPTER 5	GENERAL SUPPORT MAINTENANCE.....	5-1
Section I	Repair Parts, Special Tools, TMDE, and Support Equipment.....	5-1
Section II	Troubleshooting.....	5-1
Section III	Maintenance Procedures.....	5-1
APPENDIX A	REFERENCES	A-1
	B MAINTENANCE ALLOCATION CHART (MAC).....	B-1
	C COMPONENTS OF END ITEM AND BASIC ISSUE ITEMS LISTS	C-1
	D ADDITIONAL AUTHORIZATON LIST (AAL).....	D-1
	E EXPENDABLE SUPPLIES AND MATERIALS LIST	E-1
	SUBJECT INDEX.....	INDEX-1

HOW TO USE THIS MANUAL

This manual tells you about your Digital Multimeter, AN/PSM-45A, and contains instructions about how to use it while testing and maintaining other equipment.

The technical manual for the electronic equipment you are maintaining will give you some guidance in the correct method to make certain connections when you are testing and troubleshooting with the multimeter.

When you first receive your multimeter, start at the front of the manual and go all the way through to the back. Become familiar with every part of the manual and the multimeter.

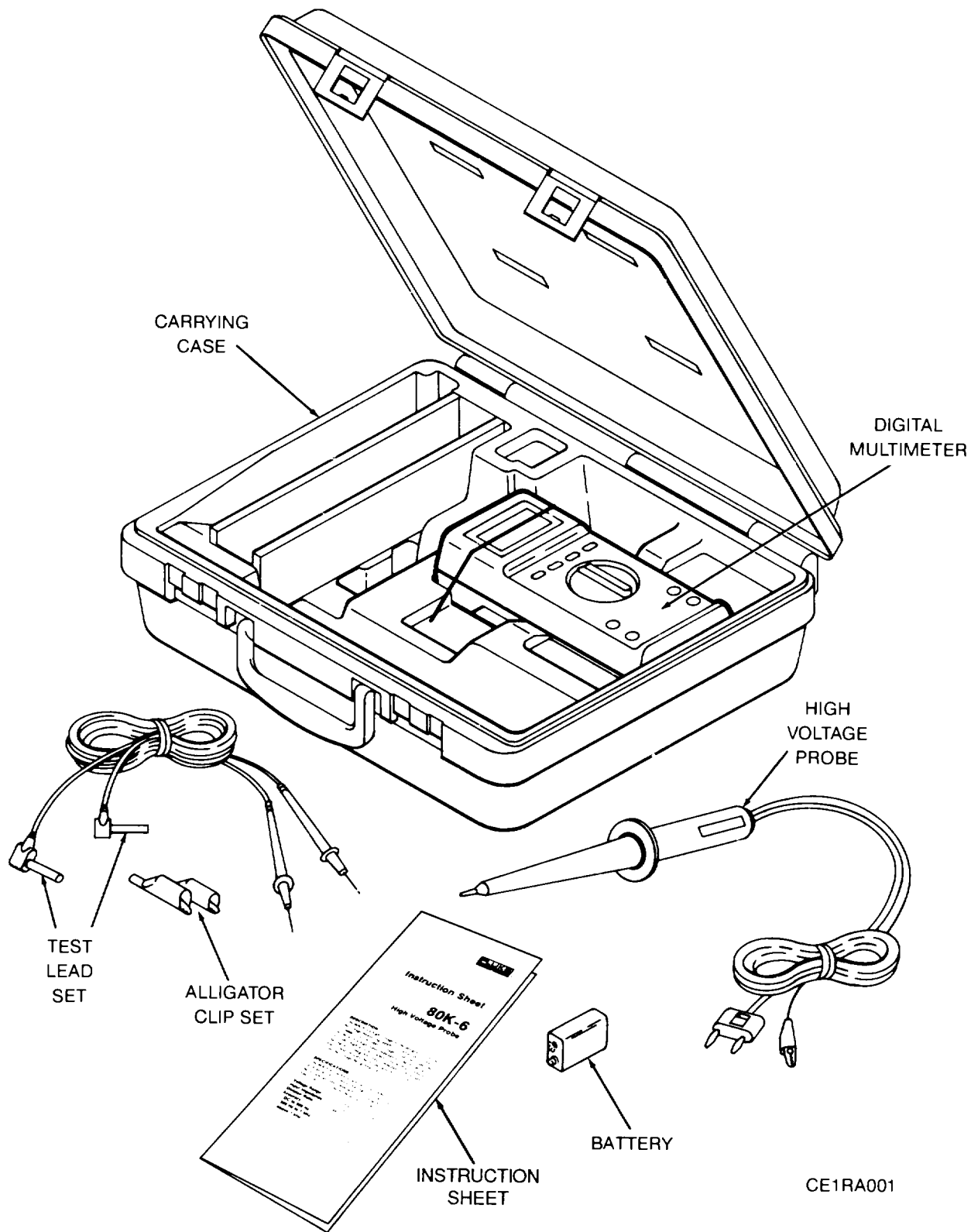

Figure 1-1. Digital Multimeter AN/PSM-45A

CHAPTER 1 INTRODUCTION

	Para	Page
Administrative Storage	1-4	1-1
Consolidated Army Publications and Forms Index	1-2	1-1
Destruction of Army Electronics Materiel	1-5	1-1
Equipment Characteristics, Capabilities, and Features	1-10	1-2
Equipment Data	1-11	1-3
General Functional Description	1-12	1-6
List of Abbreviations	1-9	1-2
Maintenance Forms, Records, and Reports	1-3	1-1
Nomenclature Cross-Reference List	1-8	1-2
Reporting Equipment Improvement Recommendations (EIR)	1-6	1-2
Scope	1-1	1-1
Warranty Information	1-7	1-2

Section I. GENERAL INFORMATION

1-1. SCOPE.

a. **Type of manual.** Operator's, Unit and Intermediate Direct Support, and General Support Maintenance Manual.

b. **Equipment Name and Model Number.** Digital Multimeter, AN/PSM-45A.

c. **Purpose of the Equipment.** The Digital Multimeter measures and indicates various electrical characteristics needed to test and troubleshoot electrical equipment.

1-2. CONSOLIDATED ARMY PUBLICATIONS AND FORMS INDEX.

Refer to the latest issue of DA Pam 25-30 to determine whether there are new editions, changes, or additional publications pertaining to the equipment.

1-3. MAINTENANCE FORMS, RECORDS, AND REPORTS.

a. **Reports of Maintenance and Unsatisfactory Equipment.** Department of the Army forms and procedures used for equipment maintenance will be those prescribed by DA Pam 750-8, as contained in The Army Maintenance Management System (TAMMS) Users Manual.

b. **Reporting of Item and Packaging Discrepancies.** Fill out and forward SF 364 (Report of Discrepancy (ROD)) as prescribed in AR 735-11-2/DLAI 4140.55/SECNAVINST 4355.18A/AFJMAN 23-215.

c. **Transportation Discrepancy Report (TDR) (SF 361).** Fill out and forward Transportation Discrepancy Report (TDR) (SF 361) as prescribed in DA Pam 25-30.

1-4. ADMINISTRATIVE STORAGE.

When removing the equipment from administrative storage perform the Operational Test (para 3-8).

1-5. DESTRUCTION OF ARMY ELECTRONICS MATERIEL.

Destruction of Army electronics materiel to prevent enemy use shall be in accordance with TM 750-244-2.

1-6. REPORTING EQUIPMENT IMPROVEMENT RECOMMENDATIONS (EIR).

If your Digital Multimeter, AN/PSM-45A, needs improvement, let us know. Send us an EIR. You, the user, are the only one who can tell us what you don't like about your equipment. Let us know why you don't like the design or performance. Put it on an SF 368 (Product Quality Deficiency Report). Mail it to: Commander, US Army Aviation and Missile Command, AMSAM-MMC-MA-NM, Redstone Arsenal, AL 35898-5000. We'll send you a reply.

1-7. WARRANTY INFORMATION.

The Digital Multimeter, AN/PSM-45A, is warranted for 12 months by the John Fluke Mfg. Co., Inc. for 13 months. The warranty starts on the date of shipment to the original buyer. Report all defects in material or workmanship to your supervisor, who will take appropriate action.

1-8. NOMENCLATURE CROSS-REFERENCE LIST.

Common names will be used when major components of the Digital Multimeter are mentioned in this manual.

NOTE

Official nomenclatures must be used when filling out report forms or looking up technical manuals.

Common Name	Official Nomenclature
Digital Multimeter	Digital Multimeter, AN/PSM-45A
Multimeter	Digital Multimeter, AN/PSM-45A

1-9. LIST OF ABBREVIATIONS.

This list identifies abbreviations and descriptions that are used in this manual.

a/d	analog to digital
IC	integrated circuit
LCD	liquid-crystal display
ROM	read-only memory

Section II. EQUIPMENT DESCRIPTION

1-10. EQUIPMENT CHARACTERISTICS, CAPABILITIES, AND FEATURES.

a. CHARACTERISTICS.

- Measures ac and dc voltage.
- Measures ac and dc current.
- Measures resistance.
- Measures conductance.
- Measures diode voltage.

b. CAPABILITIES AND FEATURES.

- 3200-count digital display.
- High voltage probe extends voltage measurement capability to 6000V.
- 1000:1 voltage divider provides high input impedance.

1-11. EQUIPMENT DATA.

WEIGHTS AND DIMENSIONS

Weight	1.6 lbs (0.73 kg)
Height	2.2 in. (5.6 cm)
Length	8 in. (20.3 cm)
Width	3.75 in. (9.5 cm)

POWER REQUIREMENTS

Battery Type	9V, BA-3090/U
Battery Life,	750 hours typical

ENVIRONMENTAL

Operating Temperature Range	-15 to +55°C (5 to 131°F); may be used to -40°C (-40°F) for 20 minutes when taken from 20°C (68°F)
Storage Temperature Range	-55 to +85°C (67 to +185°F)
Relative Humidity	<95% at 0 to 35°C (32 to 95°F) <70% at 35 to 55°C (95 to 131°F)
Shock, Vibration, and Water Resistance	Per MIL-T-28800 for a Style A, Class 2 instrument

SAFETY

Protection Class II per IEC 348 and ANSI C39.5

INPUT CHARACTERISTICS

Maximum input Voltage	1000V between any terminal and earth ground
Fuse Protection	1A 600V Fast, 15A 600V Fast

ACCURACY, GENERAL

Accuracy Statements	Accuracy is specified as $\pm[(\% \text{ of reading}) + (\text{number of least-significant digits})]$
Basic Electrical Accuracy	Specified from 18 to 28°C(64to 82°F), at a relative humidity of up to 95%, for one year after calibration
Temperature Coefficient	0.1 x (specified accuracy)/°C<18°C(64°F) or >28°C(82°F)

PERFORMANCE, DC VOLTS

Accuracy	$\pm(0.1\% + 1 \text{ digit})$
Resolution:	
320 mV range	0.1 mV
3.2V range	0.001V
32V range	0.01V
320V range	0.1V
1000V range	1V
Overload Protection: 320 mV range	750Vrms
3.2V, 32V, 320V, and 1000V ranges	1000V rms
Input Impedance (nominal)	10 megohms in parallel with< 100pF
Common Mode Rejection Ratio (1 kilohm unbalance)	>120 dB at dc, 50 Hz or 60 Hz
Normal Mode Rejection	>60 dB at 50 Hz or 60 Hz

PERFORMANCE, AC VOLTS

General:

AC Conversion Method AC coupled, true rms responding to signals
 whose crest factor is 3:1 or less

Accuracy Within a single ac range, accuracy is specified between 5 and 100% of full range

Accuracy:

20 to 40 Hz $\pm(1.5\% + 5 \text{ digits})$
 40 Hz to 1 kHz $\pm(0.5 + 5 \text{ digits})$
 1 to 5 kHz $\pm(5\% + 5 \text{ digits})$

Resolution:

320 mV range 0.1 mV
 3.2V range 0.001V
 32V range 0.01V
 320V range 0.1V
 1000V range 1V

Overload Protection:

320 mV ranges 750V rms
 3.2V, 32V, 320V, and 1000V ranges 1000V rms

Input Impedance (nominal) 10 megohms in parallel with $< 100\text{pf}$
 Common Mode Rejection Ratio (1 kilohm unbalance) $>60\text{dB}$, dc to 60 Hz

PERFORMANCE, DC CURRENT

Accuracy:

320 μA , 3200 μA , 32mA, and 320 mA ranges $\pm(0.75\% + 2 \text{ digits})$
 10A range $\pm(1.75\% + 2 \text{ digits})$

Resolution:

320 μA range 0.1 μA
 3200 μA range 1 μA
 32 mA range 0.01 mA
 320 mA range 0.1 mA
 10A range 0.01A

Burden Rate (typical):

320 μA and 3200 μA range 0.5 mV/ μA
 32 mA and 320 mA range 6mV/mA
 10A range 50mV/A

PERFORMANCE, AC CURRENT

General:

AC Conversion Method AC coupled, true rms responding to signals
 whose crest factor is 3:1 or less

Accuracy Within a single ac range, accuracy is specified between 5 and 100% of full range

Accuracy (20 to 40 Hz):

320 μA , 3200 μA , 32 mA, and 320 mA ranges $\pm(2\% + 5 \text{ digits})$
 10A ranges $\pm(3\% + 5 \text{ digits})$

Accuracy (40 Hz to 1 kHz):

320 μ A, 3200 μ A, 32 mA, and 320 mA ranges	$\pm(1.50\% + 5 \text{ digits})$
10A range	$\pm(2.50\% + 5 \text{ digits})$

Resolution:

320 μ A range	0.1 μ A
3200 μ A range	1 μ A
32 mA range	0.01 mA
320 mA range	0.1 mA
10A range	0.01A

Burden Rate (typical):

320 μ A and 3200 μ A range	0.5 mV/ μ A
32 mA and 320 mA range	6mV/mA
10A range	50mV/A

PERFORMANCE, RESISTANCE

Accuracy:

320 ohm range	$\pm(0.3\% + 2 \text{ digits})$
3.2 kilohm, 32 kilohm, 320 kilohm, and 3.2 megohm ranges	$\pm(0.25\% + 1 \text{ digit})$
32 megohm range	$\pm(1\% + 1 \text{ digit})$
32 nS (conductance)	$\pm(2\% + 10 \text{ digits})$ typical

Resolution:

320 ohm range	0.1 ohm
3.2 kilohm range	0.001 kilohm
32 kilohm range	0.01 kilohm
320 kilohm range	0.1 kilohm
3.2 megohm range	0.001 megohm
32 megohm range	0.01 megohm
32 nS (conductance)	0.01 nS

Overload Protection	750V rms
Open Circuit Test Voltage	<2.8V dc

Full Scale Voltage:

Up to 3.2 megohms	<420 mV dc
32 megohms or nS	<1.3V dc

PERFORMANCE, DIODE AND CONTINUITY TEST

Accuracy	$\pm(1\% + 1 \text{ digit})$ typical
Resolution (2.000V range)	0.001V
Continuity Test	beeper emits a continuous tone at test resistance below approximately 150 ohms

HIGH VOLTAGE PROBE

Voltage Range	0 to 6kV, dc or peak ac
Input Impedance	75 megohms \pm 25 megohms
Division Ratio	1000:1

Accuracy:

DC to 1 kHz	$\pm 5\%$
Above 1 kHz	output reading falls (typically, -30% at 10 kHz)

Section III. TECHNICAL PRINCIPLES OF OPERATION

1-12. GENERAL FUNCTIONAL DESCRIPTION.

Digital Multimeter AN/PSM-45A (fig. 1-2) measures ac/dc voltages, ac/dc currents, resistance, and conductance. The multi meter is composed of two major functional sections: the analog section and the digital section.

- ① The U1 custom analog IC (integrated circuit) contains the a/d (analog-to-digital) converter, signal-conditioning circuits, and the digital control circuitry required for communication with the microcomputer. Although the custom IC is primarily analog, digital circuits provide state machine control for the a/d converter, a read counter for a/d samples, decoding ROMs (read-only memories) for analog switch drive, and bus control for communication with the microcomputer.
- ② The microcomputer controls the a/d converter, initiates the range and function switching, formats data for display, and drives the display.
- ③ The mode push buttons supply input to the microcomputer to initiate various modes.
- ④ The liquid crystal display (LCD) displays output from the microcomputer.
- ⑤ Input overload protection for the volts/ohms/diode-test input (J 1) is provided by a network of five metal-oxide varistors and two current-limiting resistors.
- ⑥ The function switch is a rotary switch with two double-sided wafers that provide the necessary switching to select each of the various functions. Battery voltage is routed through the function switch from the battery voltage regulator to U1 and from U1 to U2. Input signals are routed from the overload protection circuits to the function switch.
- ⑦ The signal conditioning circuits receive each input signal before it reaches U 1. The precision resistor network provides precise input scaling for the various voltage ranges and precision reference resistors for the ohms function.
- ⑧ Reference voltage for the a/d converter is supplied by the voltage regulator and its associated components. The voltage regulator supplies a regulated 1.000V reference voltage.
- ⑨ The battery voltage regulator circuit supplies consistent operating power to U 1 and (through a second regulator circuit in U 1) to the microcomputer (U2).

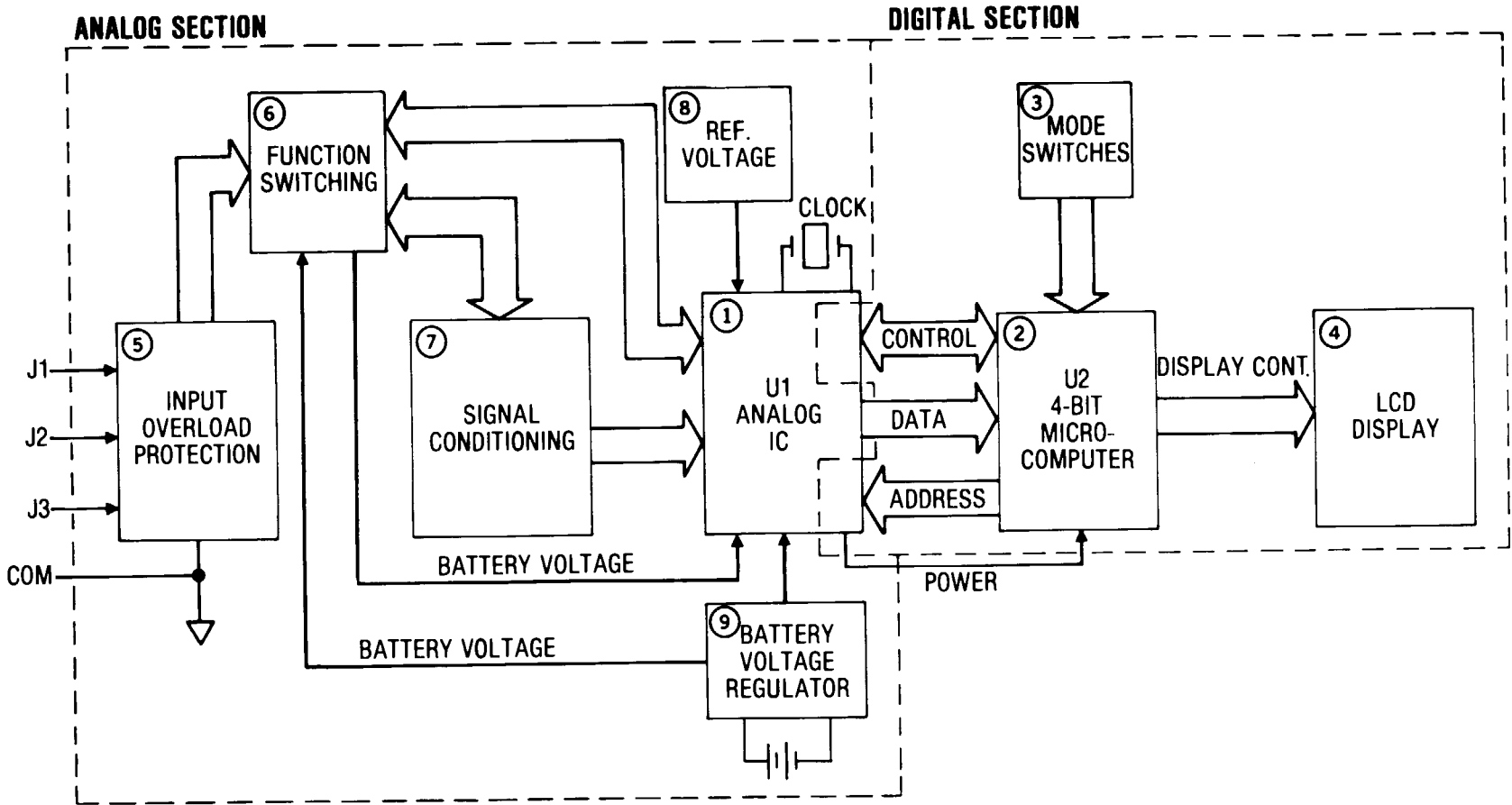

Figure 1-2. Digital Multimeter AN/PSM-45A Simplified Block Diagram

CHAPTER 2 OPERATING INSTRUCTIONS

	Para	Page
AC Current Measurements.....	2-9	2-10
AC Voltage Measurements.....	2-6	2-6
Conductance Measurements.....	2-11	2-13
Continuity Measurements.....	2-12	2-15
DC Current Measurements.....	2-8	2-8
DC Voltage Measurements.....	2-5	2-5
Diode Test.....	2-13	2-16
High Voltage Measurements.....	2-7	2-7
Introduction.....	2-1	2-1
Introduction.....	2-2	2-4
Manual Range Mode.....	2-14	2-18
Min/Max Mode.....	2-16	2-21
Operating Procedures,.....	2-4	2-4
Operation In Extreme Heat and Extreme Cold.....	2-18	2-24
Operation in Wet Weather.....	2-19	2-24
Relative Mode.....	2-15	2-20
Resistance Measurements.....	2-10	2-12
Touch-Hold Measurements.....	2-17	2-22
Power-on Self Test.....	2-3	2-4

Section I. DESCRIPTION AND USE OF OPERATOR'S CONTROLS, INDICATORS, AND CONNECTORS

2-1. INTRODUCTION.

This section describes all of the operator controls, indicators, and connectors for the multimeter.

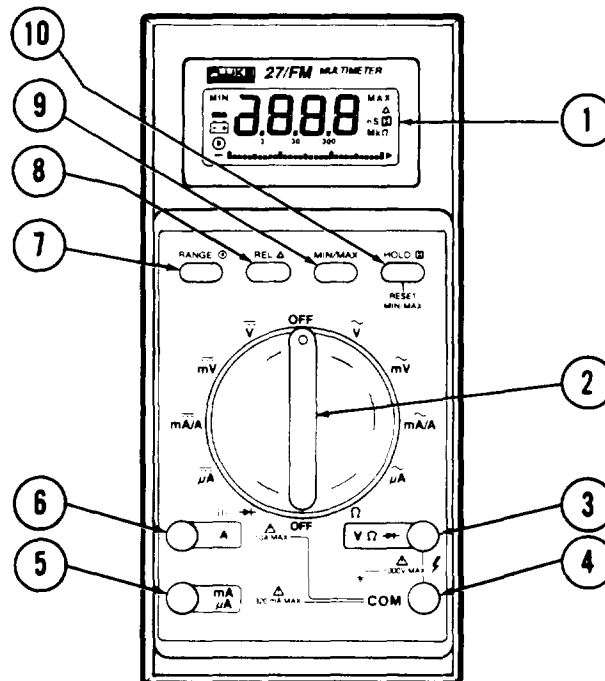

KEY	CONTROL, INDICATOR OR CONNECTOR	FUNCTION																				
1	Digital Display	3200-count, liquid crystal display (LCD) with automatic decimal point positioning. Updated 2 1/2 times per second. When the multimeter is first turned on, all display segments appear while the instrument performs a brief power-on self test.																				
2	Function Selector Rotary Switch	<p>Selects one of ten functions (or OFF) by pointing to the desired function. The symbols and corresponding functions are as follows:</p> <table style="margin-left: auto; margin-right: auto;"> <tr> <td style="text-align: center;">~ V</td> <td>ac volts</td> </tr> <tr> <td style="text-align: center;">~ mV</td> <td>ac millivolts</td> </tr> <tr> <td style="text-align: center;">~ mA/A</td> <td>ac milliamps or amps</td> </tr> <tr> <td style="text-align: center;">~ μA</td> <td>ac microamps</td> </tr> <tr> <td style="text-align: center;">Ω</td> <td>ohms</td> </tr> <tr> <td style="text-align: center;"> →</td> <td>beeper diode</td> </tr> <tr> <td style="text-align: center;">— μA</td> <td>dc microamps</td> </tr> <tr> <td style="text-align: center;">— mA/A</td> <td>dc milliamps or amps</td> </tr> <tr> <td style="text-align: center;">— mV</td> <td>dc millivolts</td> </tr> <tr> <td style="text-align: center;">— V</td> <td>dc volts</td> </tr> </table>	~ V	ac volts	~ mV	ac millivolts	~ mA/A	ac milliamps or amps	~ μA	ac microamps	Ω	ohms	→	beeper diode	— μA	dc microamps	— mA/A	dc milliamps or amps	— mV	dc millivolts	— V	dc volts
~ V	ac volts																					
~ mV	ac millivolts																					
~ mA/A	ac milliamps or amps																					
~ μA	ac microamps																					
Ω	ohms																					
→	beeper diode																					
— μA	dc microamps																					
— mA/A	dc milliamps or amps																					
— mV	dc millivolts																					
— V	dc volts																					
3	Volts, Ohms, Diode (V/ Ω/ diode) Input Terminal	Input terminal used in conjunction with the volts, mV (ac or dc), ohms, or diode position of the function selector rotary switch.																				
4	COM Terminal	Common or return terminal used for all measurements.																				
5	mA/μA Input Terminal	Input terminal used for current measurements up to 320 mA (ac or dc) with the function selector rotary switch in the mA or PA position,																				
6	A (amps) Input Terminal	Input terminal used for current measurements up to 10A continuous (20A for 30 seconds) with the function selector rotary switch in the mA/A position (ac or dc).																				
7	Manual Range Mode Key	Enables manual ranging. The multimeter powers up in autorange.																				
8	Relative Mode Key	Stores a digital reading and displays the change (difference) between the stored reading and any following reading. If the difference exceeds 3999 counts (without overloading the input), OF (overflow) is displayed. The relative mode selects manual ranging; changing ranges automatically exits the relative mode.																				
9	MIN/MAX Mode Key	Used to store the minimum and maximum readings of the multimeter, and displays either reading as selected by the operator. The MIN/ MAX mode automatically selects manual ranging. Range changes reset previously recorded MIN/MAX readings. Exiting the MIN/MAX mode does not reset the previously recorded readings unless the range or function is changed. The MIN/ MAX mode overrides the touch-hold mode.																				
10	Touch-Hold Mode Key	Used to capture a stable measurement and hold the measurement on the display. The multimeter beeps and the display is automatically updated each time a new, stable measurement is made. Automatic touch-hold updates can be defeated to allow the readings to be updated only when the HOLD key is pressed.																				

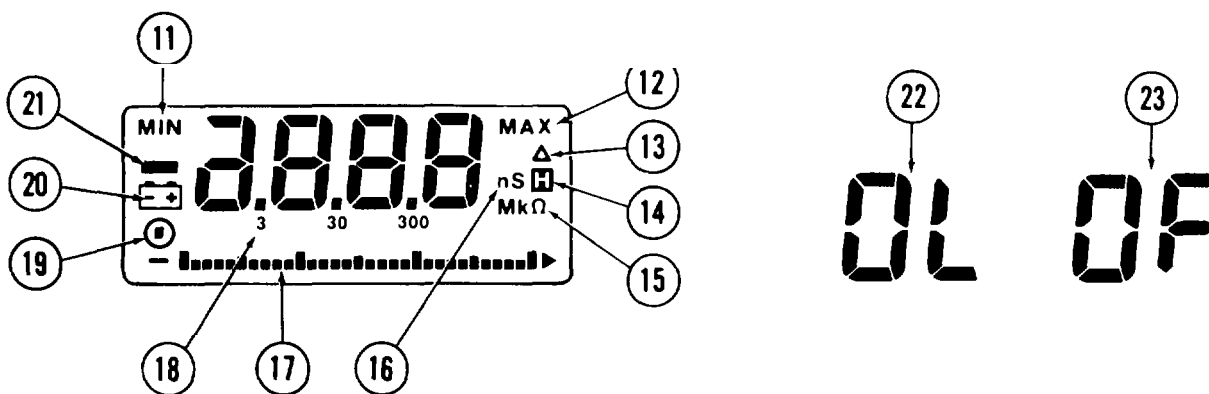

KEY	CONTROL, INDICATOR, OR CONNECTOR	FUNCTION
11	Minimum Value Annunciator	Indicates that the multimeter is in the MIN/MAX recording mode, and the value displayed is the minimum digital reading taken since reset or since entering MIN/MAX.
12	Maximum Value Annunciator	Indicates that the multimeter is in the MIN/MAX recording mode, and the value displayed is the maximum digital reading taken since reset or since entering MIN/MAX.
13	Relative Value Annunciator	Indicates that the multi meter is in the relative mode, and the value displayed is relative (the difference between the present measurement and the previously stored reading).
14	Touch-Hold Mode Annunciator	Displayed when the touch-hold mode is in use.
15	Resistance Annunciators	The appropriate annunciator (Ω , κ , or M) is displayed for the resistance range in use.
16	Conductance Range Annunciator	Top range of the resistance function is the conductance range. Displays conductance in nS (nanosiemens). 1000/nS converts to megohm. Used for measuring resistance above 32 megohms.
17	Analog Bar Graph Display	Analog representation of input. Composed of 31 segments that illuminate starting from the left as the input increases. A bar (-) is displayed when the input level is within 10 counts of zero.
18	Decimal Point, Range Indicator	Decimal point position and the digits (3, 30, 300) under the decimal point indicate the range in USC.
19	Manual Range Annunciator	Displayed in the manual range mode or if the selected function has only one range. Absence of the annunciator implies autorange mode in use.
20	Low Battery Annunciator	At least 40 hours of battery life remain when first displayed. Battery voltage is tested each time the function switch is moved to a new position.
21	Negative Polarity Annunciator	Automatically indicates negative inputs.
22	Overload Indication	Indicates that the input is too large for the input circuitry.
23	Overflow Indication	Indicates that the calculated difference in the relative mode is too large to display (>3999 counts) and that the input is not overloaded.

Section II. OPERATION UNDER USUAL CONDITIONS

2-2. INTRODUCTION.

This section provides the information required to operate the multimeter in each measurement function: dc and ac voltage, dc and ac current, resistance, conductance, continuity, and diode test.

2-3. POWER-ON SELF TEST.

Perform the following steps to power up the multimeter.

- a. Turn the function selector rotary switch from OFF to any position.

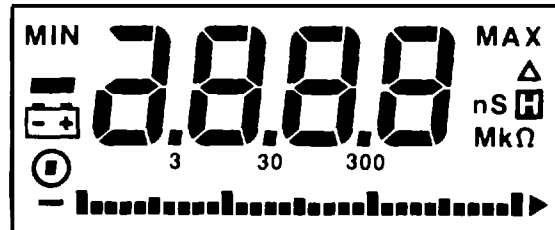

- b. Watch the display while the multimeter runs the power-on self test. All display segments are switched on for about one second and then off for about one second. The display then shows an appropriate measurement value for the selected function and range.

2-4. OPERATING PROCEDURES.

Procedures for multimeter operation are provided in paragraphs 2-5 through 2-17.

NOTE

- When multimeter power is turned on, autorange mode is automatically selected.
- If manual range mode is desired, refer to paragraph 2-14.

2-5. DC VOLTAGE MEASUREMENTS.

Perform the following steps to make a dc voltage measurement.

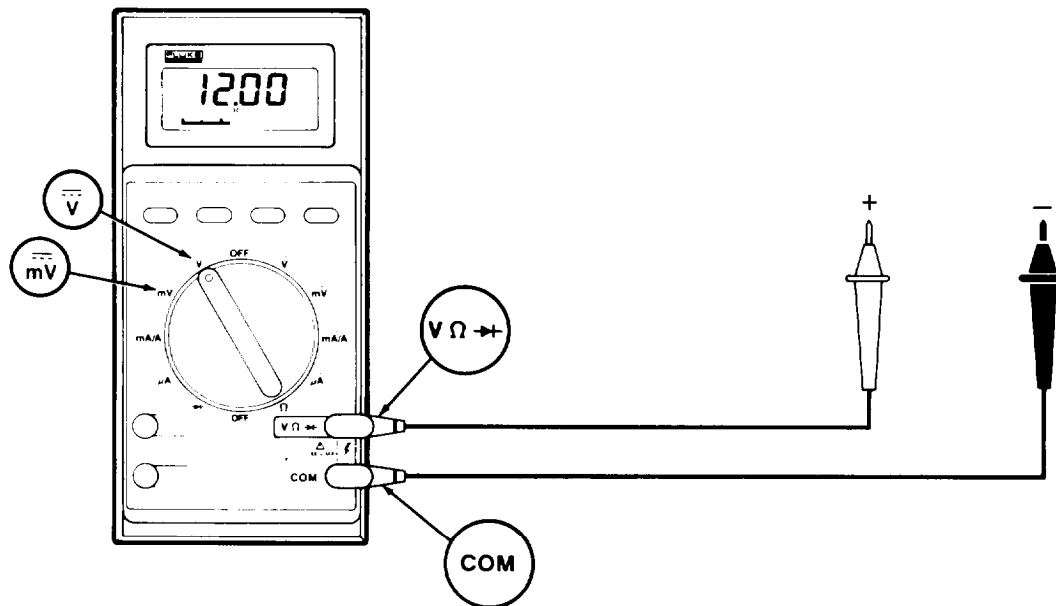

WARNING

To avoid shock hazard and/or instrument damage, do not apply input potentials greater than 1000V across the $\zeta/\Omega/$ diode and COM terminals.

- a. Connect the red test lead plug to the $\zeta/\Omega/$ diode terminal.
- b. Connect the black test lead plug to the COM terminal.
- c. Set the function selector rotary switch to the dc V function.
- d. Connect the test lead probes to the circuit being measured.
- e. Read the measured dc voltage value on the display. The display indicates correct polarity, minus (-) for negative and no sign for positive. The measured value is shown on both the numerical display and the bargraph display.
- f. If the absolute displayed value is less than 320 mV, set the function selector rotary switch to the dc mV position for maximum resolution.
- g. After the measurement is complete, disconnect the test leads from the circuit being measured.

2-6. AC VOLTAGE MEASUREMENTS.

Perform the following steps to make an ac voltage measurement.

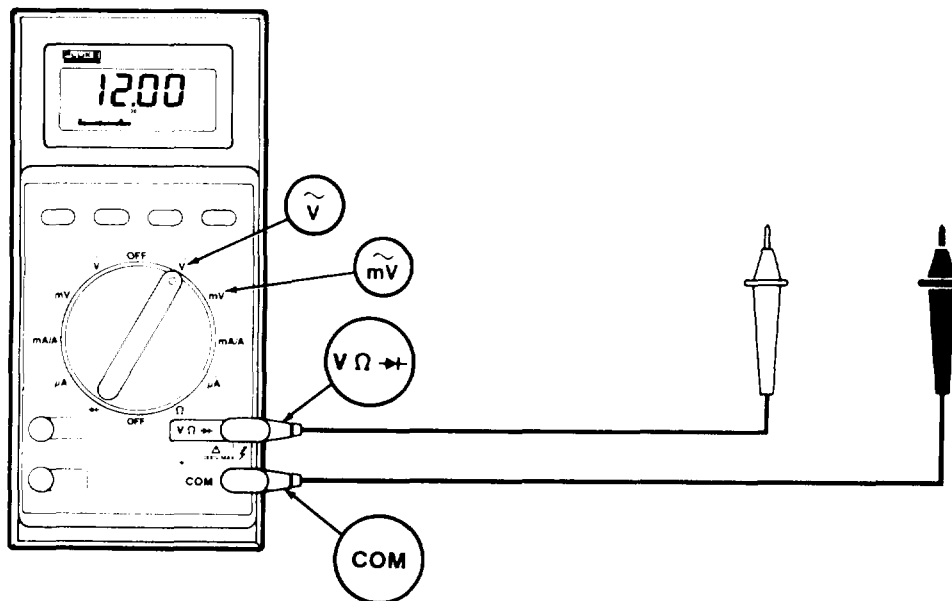

WARNING

To avoid shock hazard and/or instrument damage, do not apply input potentials greater than 1000V across the ζ/Ω /diode and COM terminals.

- a. Connect the red test lead plug to the ζ/Ω /diode terminal.
- b. Connect the black test lead plug to the COM terminal.
- c. Set the function selector rotary switch to the ac V function.
- d. Connect the test lead probes to the circuit being measured.
- e. Read the measured ac voltage value on the display. The measured value is shown on both the numerical display and the bargraph display.
- f. If the displayed value is less than 320 mV, set the function selector rotary switch to the ac mV position for maximum resolution.
- g. After the measurement is complete, disconnect the test leads from the circuit being measured.

2-7. HIGH VOLTAGE MEASUREMENTS.

Perform the following steps to make voltage measurements with the high voltage probe.

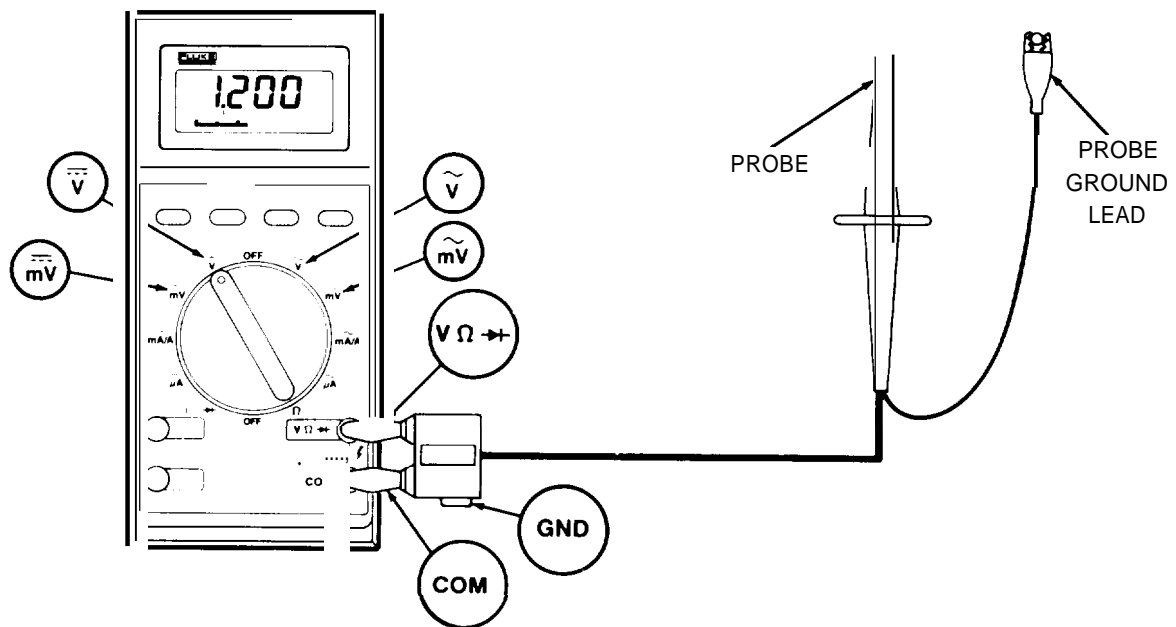

WARNING

- To avoid shock hazard, make sure the ground test lead of the high voltage probe is connected to a ground path potential below 30V ac, 42V peak, or 60V dc.
 - To avoid shock hazard and/ or instrument damage, do not apply input potentials greater than 6000V to the probe tip.
- a. Connect the dual-prong banana connector on the High Voltage Probe to the V/ Q/diode terminal and the COM terminal. Make sure the tabbed side of the plug marked GND connects to the COM terminal.
 - b. Set the function selector rotary switch to the desired measurement function, dc V or ac V.
 - c. Connect the probe to the circuit being measured in the following sequence:
 - PROBE GROUND LEAD to ground.
 - PROBE TIP to the circuit being measured.
 - d. Multiply the displayed voltage by 1000 to obtain the actual value of the measured voltage. The measured value is shown on both the numerical display and the bargraph display.
 - e. If the displayed value is less than 320 mV, set the function selector rotary switch to the appropriate dc mV/ac mV position for maximum resolution.
 - f. After the measurement is complete, disconnect the probe tip and ground lead from the circuit being measured.

2-8. DC CURRENT MEASUREMENTS.

Perform the following steps to make dc current measurements.

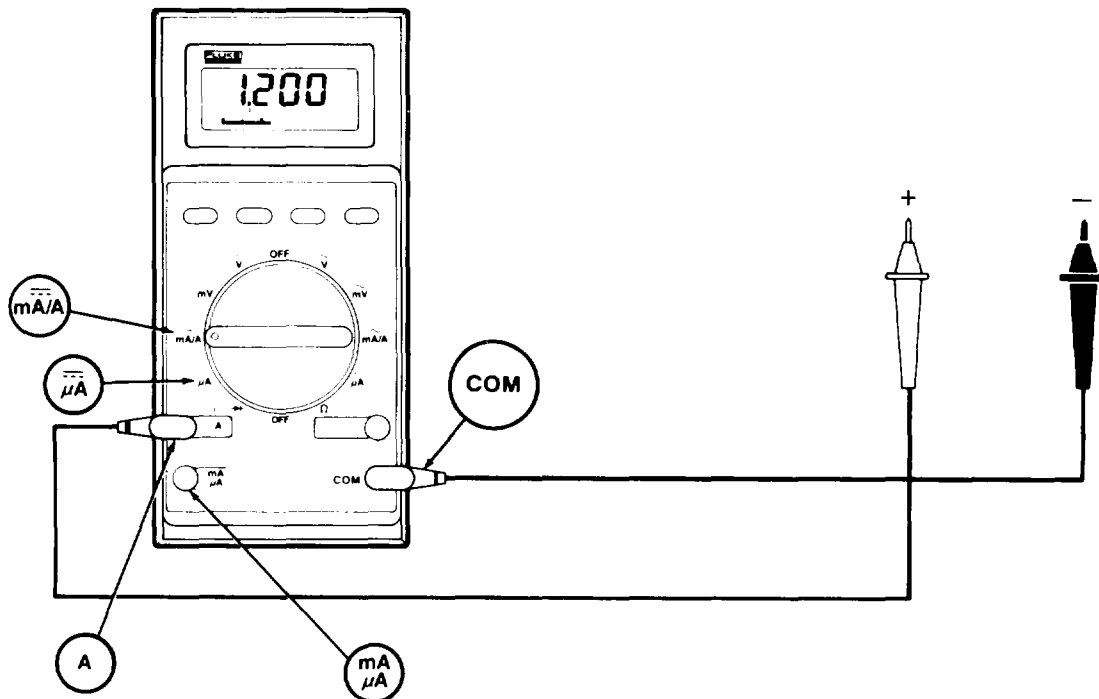

WARNING

Operator injury and/ or instrument damage may result if the fuse blows while current is being measured in a circuit that exhibits an open circuit voltage greater than 600V. Do not attempt an in-circuit current measurement where the potential is greater than 600V.

- a. Connect the red test lead plug to the A terminal.
- b. Connect the black test lead plug to the COM terminal.
- c. Set the function selector rotary switch to dc mA/A.

CAUTION

Remove all power from the circuit being measured before connecting or disconnecting the test leads.

- d. Connect the test leads in series in the circuit being measured.
- e. Apply power to the circuit being measured.
- f. Read the measured dc current value on the display. The display indicates correct polarity, minus (-) for negative and no sign for positive. The measured value is shown on both the numerical display and the bargraph display.

- g. If the absolute value displayed is less than 0.32A, and more resolution is required, continue as follows:
- (1) Remove power from the circuit being measured.
 - (2) Disconnect the test leads from the circuit being measured.
 - (3) Disconnect the red standard test lead from the A input terminal, and plug it into the $\mu\text{A}/\text{mA}$ input terminal.
 - (4) Connect the test leads in series in the circuit being measured.
 - (5) Apply power to the circuit being measured.
 - (6) Read the current value on the display. If the displayed absolute value is less than 3.20 mA (3200 μA), move the function selector rotary switch to the dc μA range.
 - (7) Read the measured dc current value on the display.
- h. After the measurement is complete, disconnect the test leads from the circuit being measured.

2-9. AC CURRENT MEASUREMENTS.

Perform the following steps to make ac current measurements.

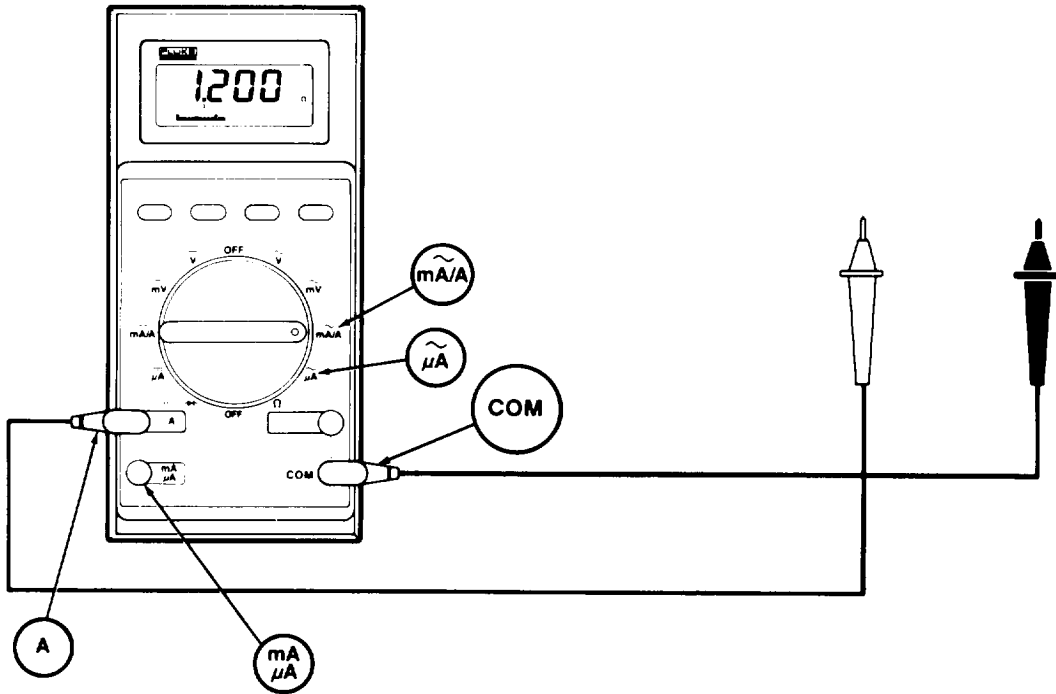

WARNING

Operator injury and/or instrument damage may result if the fuse blows while current is being measured in a circuit that exhibits an open circuit voltage greater than 600V. Do not attempt an in-circuit current measurement where the potential is greater than 600V,

- a. Connect the red test lead plug to the A terminal.
- b. Connect the black test lead plug to the COM terminal.
- c. Set the function selector rotary switch to ac mA/A.

CAUTION

Remove all power from the circuit being measured before connecting or disconnecting the test leads.

- d. Connect the test leads in series in the circuit being measured.
- e. Apply power to the circuit being measured.

f. Read the measured ac current value on the display. The measured value is shown on both the numerical display and the bargraph display.

g. If the absolute value displayed is less than 0.32A and more resolution is required, continue as follows:

- (1) Remove power from the circuit being measured.
- (2) Disconnect the test leads from the circuit being measured.
- (3) Disconnect the red test lead plug from the A terminal, and connect it to the $\mu\text{A}/\text{mA}$ terminal.
- (4) Connect the test leads in series in the circuit being measured.
- (5) Apply power to the circuit being measured.
- (6) Read the current value on the display. If the displayed absolute value is less than 3.20 mA (3200 μA), move the function selector rotary switch to the ac μA range,
- (7) Read the measured ac current value on the display.

h. After the measurement is complete, disconnect the test leads from the circuit being measured.

2-10. RESISTANCE MEASUREMENTS.

Perform the following steps to make resistance measurements,

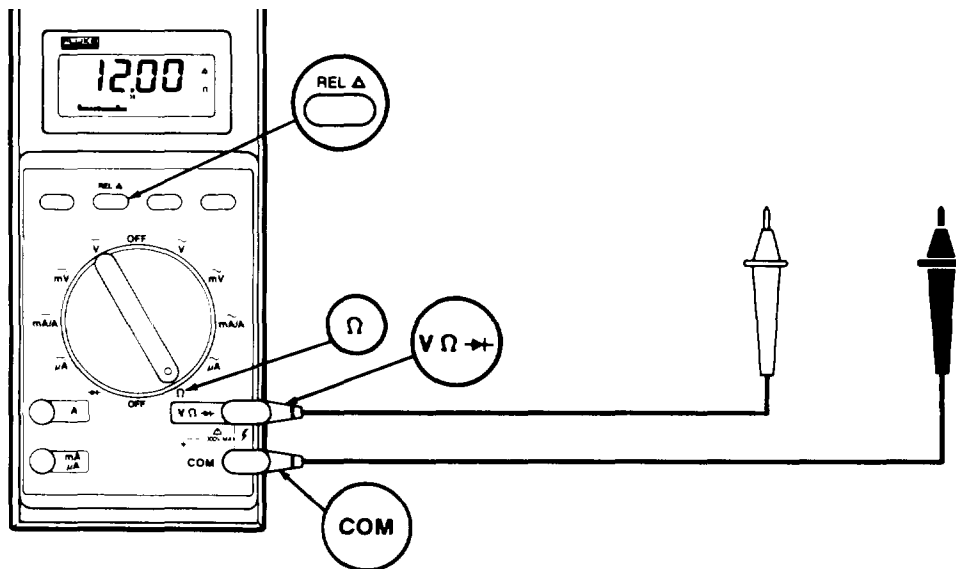

CAUTION

Accidental input of voltage greater than 750V dc or ac rms when the multimeter is in the resistance mode may damage the multimeter.

- a. Connect the red test lead plug to the Ω /diode terminal.
- b. Connect the black test lead plug to the COM terminal.
- c. Set the function selector rotary switch to the Ω function.

NOTE

When measuring low resistances, remember that test lead resistance may cause wrong readings. Test lead resistance should be subtracted from the display reading for correct readings.

- d. Short the test lead tips together and momentarily press the REL key. Test lead resistance will be automatically subtracted from all following readings.

CAUTION

Remove all power from the circuit being measured before connecting or disconnecting the test leads.

- e. Connect the test lead probes to the resistance being measured.

NOTE

Making in-circuit measurements where charged capacitors are present may result in wrong readings.

- f. Read the measured resistance value on the display. The measured value is shown on both the numerical display and the bargraph display.
- g. After the measurement is complete, disconnect the test leads from the circuit being measured.

2-11. CONDUCTANCE MEASUREMENTS.

Perform the following steps to make conductance measurements.

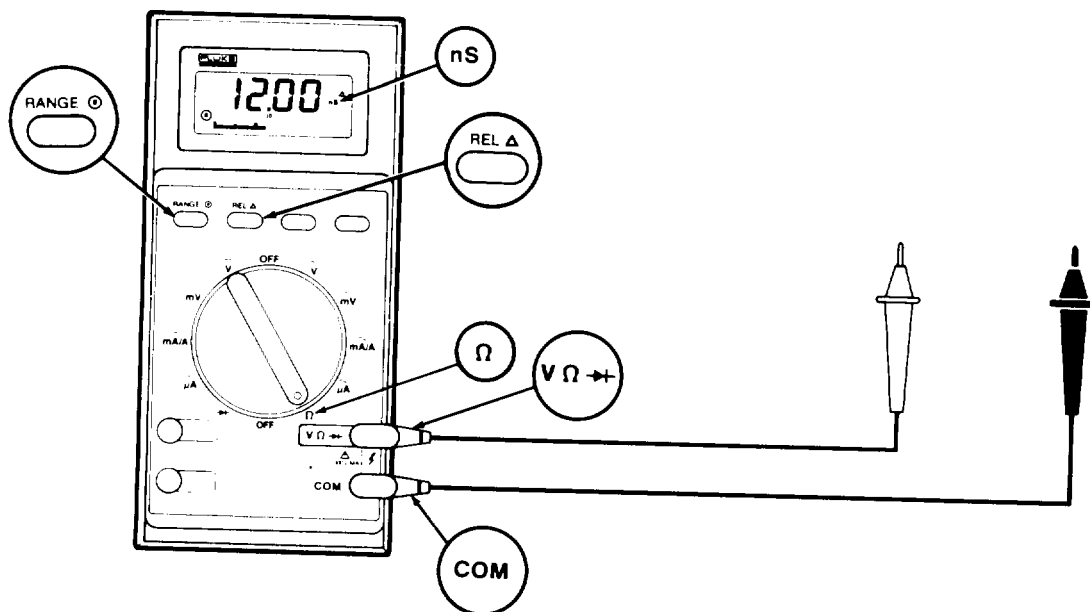
**CAUTION**

Accidental input of voltage greater than 750V dc or ac rms when the multimeter is in the resistance mode may damage the multimeter.

- a. Connect the red test lead plug to the Ω /diode terminal.
- b. Connect the black test lead plug to the COM terminal.
- c. Set the function selector rotary switch to Ω .
- d. Repeatedly press the RANGE key until the conductance range annunciator, nS, appears on the display. Conductance is measured only in manual range mode (para 2-14).

NOTE

In the conductance range, there is normally a small residual reading with open test leads. The residual reading should be subtracted from the display reading for correct readings.

- e. Hold the test leads so their tips are not touching, and allow the display to settle.
- f. After the display settles, press the REL key.

CAUTION

Remove all power from the circuit being measured before connecting or disconnecting the test leads.

- g. Connect the test leads to the conductance to be measured.

NOTE

Making in-circuit measurements where charged capacitors are present may result in wrong readings.

- h. Read the measured conductance value on the display. The measured value is shown on both the numerical display and the bargraph display.
- i. After the measurement is complete, disconnect the test leads from the circuit being measured.

2-12. CONTINUITY MEASUREMENTS.

Perform the following steps to test for continuity.

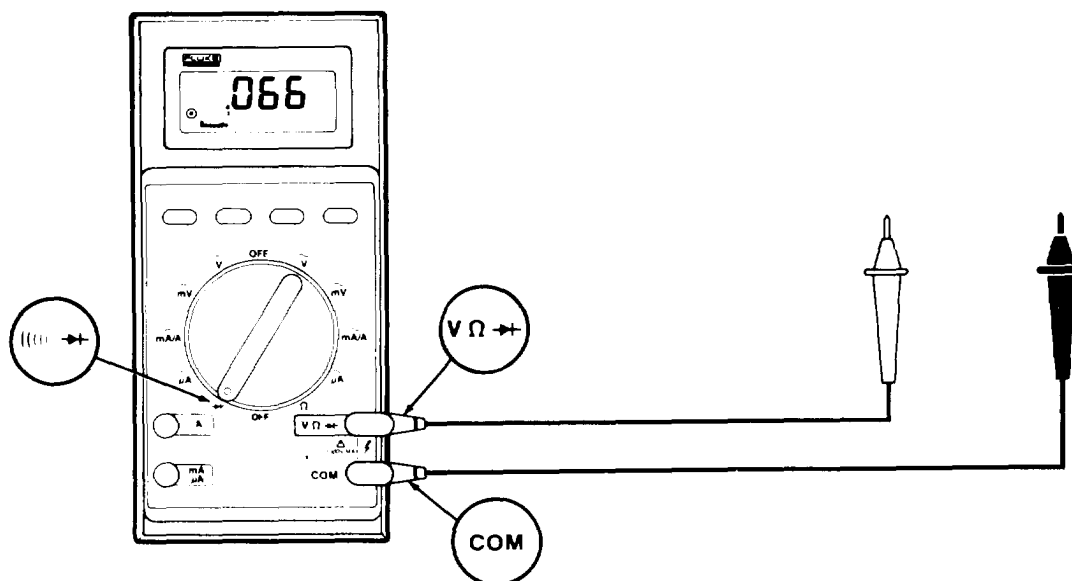
**CAUTION**

Accidental input of voltage greater than 750V dc or ac rms when the multimeter is in the beeper/ diode test (resistance) mode may damage the multimeter.

- a. Connect the red test lead plug to the V/Q/diode terminal.
- b. Connect the black test lead plug to the COM terminal.
- c. Set the function selector rotary switch to beeper/diode test.

CAUTION

Remove all power from the circuit being measured before connecting or disconnecting the test leads.

- d. Connect the test lead probes to the circuit being tested. An audible tone and an on-scale reading on the display indicate continuity.

NOTE

- A continuous tone indicates a resistance of approximately 150 ohms or less. Test resistances from approximately 150 to 1000 ohms produce a short tone.
 - Making in-circuit measurements where charged capacitors are present may result in wrong readings.
- e. After the measurement is complete, disconnect the test leads from the circuit being tested.

2-13. DIODE TEST.

Perform the following steps to test diodes.

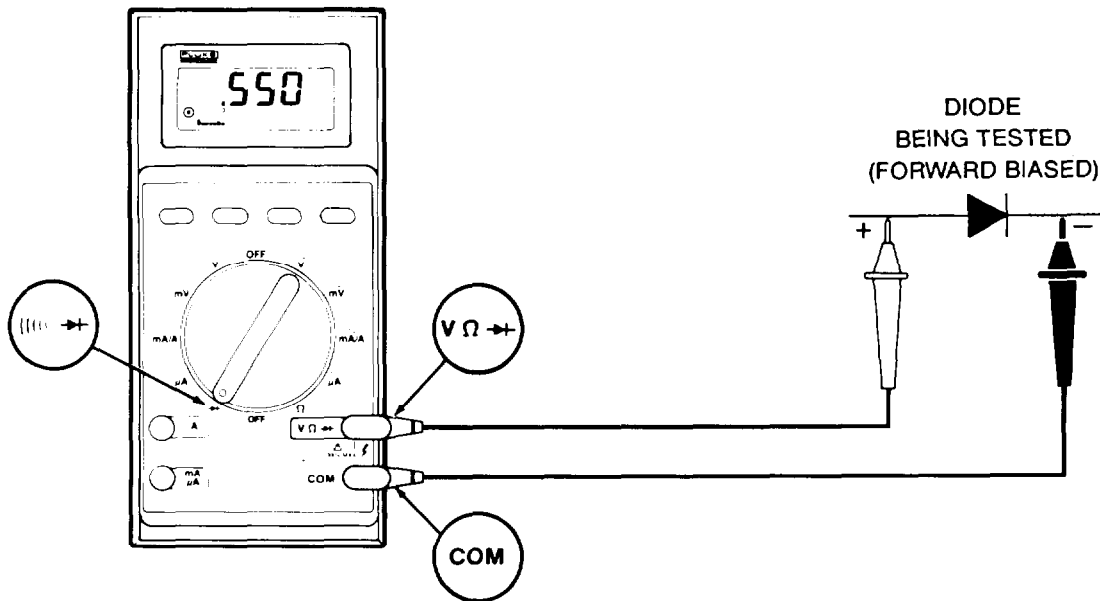

CAUTION

Accidental input of voltage greater than 750V dc or ac rms when the multimeter is in the beeper/diode test (resistance) mode may damage the multi meter.

NOTE

If the diode to be tested is in circuit, disconnect one end from the circuit to ensure an accurate reading.

- a. Connect the red test lead plug to the V/ Q/diode terminal.
- b. Connect the black test lead plug to the COM terminal.
- c. Set the function selector rotary switch to beeper/diode test.

CAUTION

Remove all power from the circuit being measured before connecting or disconnecting the test leads.

- d. Connect the test leads to the diode being tested. A momentary audible beep indicates a good forward-biased diode.

NOTE

Making in-circuit measurements where charged capacitors are present may result in wrong readings.

- e. Read the value on the display. A typical reading for a good silicon diode is usually in the range of .400 to .600.
- f. Reverse the test leads at the diode. If the diode is good, the audible beep will not occur, and the display will show an overload condition.
- g. After the measurement is complete, disconnect the test leads from the diode being tested.

2-14. MANUAL RANGE MODE.

Perform the following steps to enable and use the manual range mode.

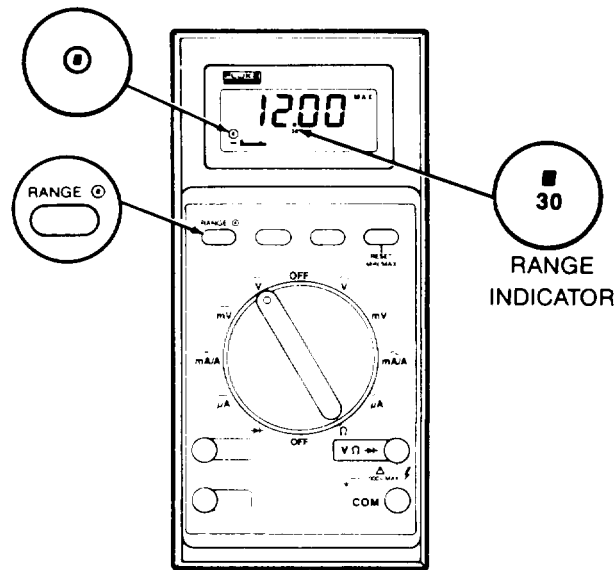

NOTE

The manual range mode works with all measurement functions except beeper/diode test, dc mV, and ac mV. These three are single range functions.

- a. Set the function selector rotary switch to the desired function.
- b. Momentarily press the RANGE key to enable the manual range mode. The manual range annunciator appears on the display.
- c. Momentarily press the RANGE key until the desired range is shown on the range indicator. The following ranges are available for each measurement function:

FUNCTION	AVAILABLE RANGES						
dc/acV	1000	300	30	3			
dc/acmV	300						
dc/ac A	10						
dc/ ac mA	300	30					
dc/acμA	3000	300					
Ω	30nS	30M	3M	300k	30k	3k	300
beeper diode	3						

d. To return to the autorange mode, use one of the following methods:

(1) Press and hold the RANGE key for two seconds. The manual range annunciator disappears from the display.

(2) Move the function selector rotary switch to another position.

NOTE

There is no autorange annunciator; absence of the manual range annunciator indicates the multimeter is in autorange.

e. To keep the multimeter from returning automatically from the manual range mode to the autorange mode:

(1) Set the function selector rotary switch to OFF.

(2) Press and hold the RANGE key. Then move the function selector rotary switch from the OFF position to any other position, Continue to hold the RANGE key down until the completion of the power-on self test.

2-15. RELATIVE MODE.

Relative mode measurements are made in conjunction with the procedures in paragraphs 2-5 through 2-14 and paragraph 2-16.

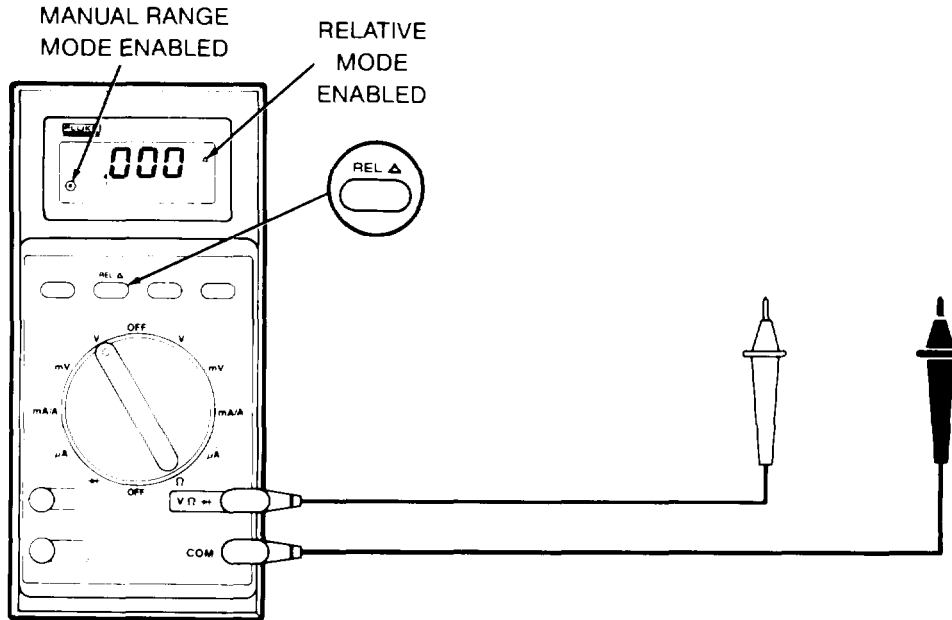

WARNING

To avoid shock hazard and/or instrument damage, be aware that in the relative mode displayed readings are relative. That is, display readings may not indicate the presence of dangerous potentials at the input connectors or test leads.

NOTE

- Relative mode stores a digital reading and displays the difference between the stored reading and any following reading. If the difference exceeds 3999 counts (without overloading the input), OF is displayed.
 - Manual ranging is selected when entering the relative mode.
 - Changing ranges or selecting autorange exits the relative mode.
- a. Make a measurement that provides an on-scale numeric display. Any function may be used.
 - b. Press the REL key momentarily to enter the relative mode and store the displayed reading. The numeric display will read zero. The bargraph continues to indicate the actual value of the input.
 - c. Change the value of the measured input. The display will read a value relative to the stored input.
 - d. To store new readings, press the REL key again,
 - e. To exit relative mode, press and hold the REL key for two seconds.

2-16. MIN/MAX MODE.

MIN/MAX mode measurements are made in conjunction with the procedures in paragraphs 2-5 through 2-15.

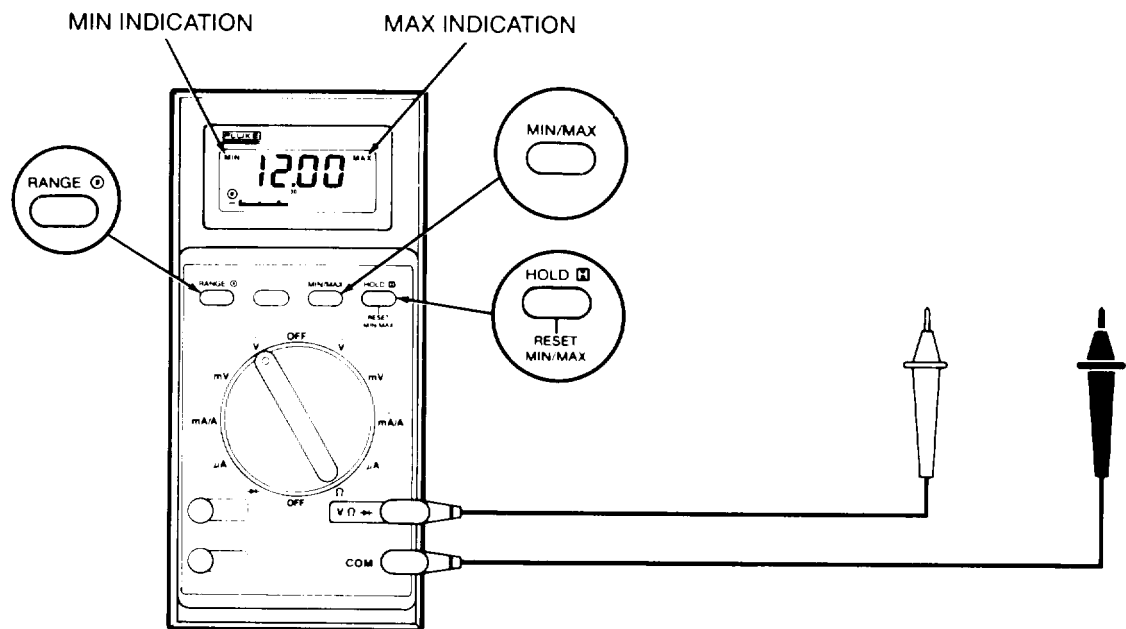
**NOTE**

Manual ranging is selected upon entering the MIN/MAX mode.

Moving the function selector rotary switch exits the MIN/MAX mode.

The bargraph is disabled for all measurement functions except beeper/diode and Ω (resistance).

- a. Select the desired measurement function.
- b. Connect the test leads to the circuit to be monitored.
- c. Press the MIN/MAX key to enter the MIN/MAX mode.
- d. Select the desired measurement range.
- e. Momentarily press the MIN/MAX key again to toggle between the MIN and MAX indications. The MAX indication displays the highest value measured. The MIN indication displays the lowest value measured.
- f. Press the HOLD RESET key to reset the MIN/MAX readings to the present input value.
- g. To exit the MIN/MAX mode, use one of the following methods:
 - (1) Press and hold the MIN/MAX key for two seconds.
 - (2) Change the position of the function selector rotary switch.

2-17. TOUCH-HOLD MEASUREMENTS.

NOTE

In touch-hold mode, the display can be updated automatically or manually.

Perform the following steps to select the touch-hold mode with automatic updating. Touch-hold measurements are made in conjunction with the procedures in paragraphs 2-5 through 2-15.

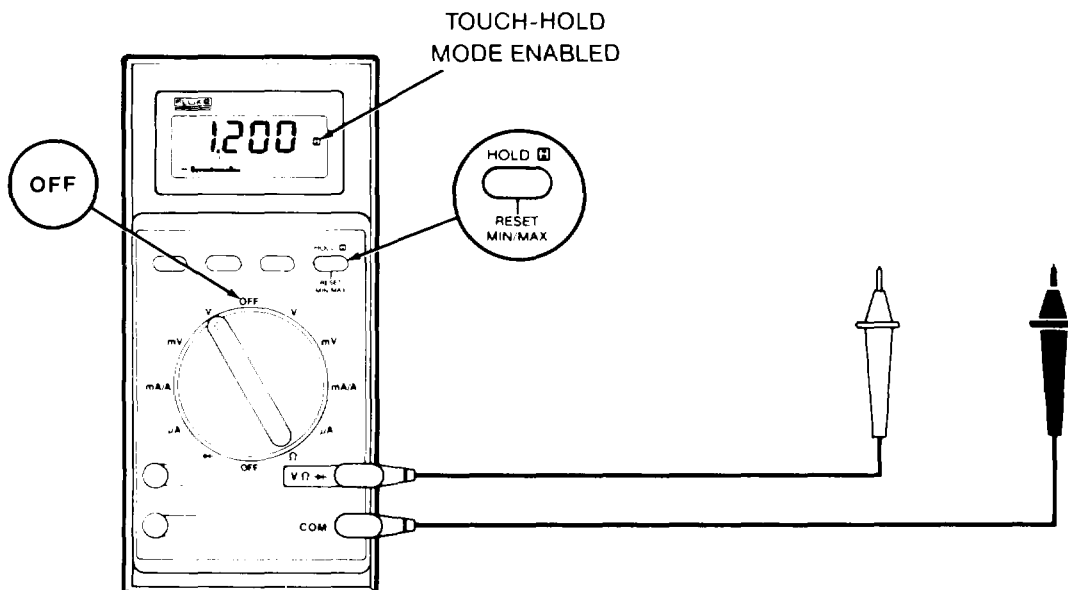

- a. Set the function selector rotary switch to the desired function.
- b. Momentarily press the HOLD key to enable the touch-hold mode.
- c. Make the intended measurement. The numeric display will hold a stabilized measurement reading. If the measurement value changes, the numeric display will automatically update and hold the newly stabilized reading.

NOTE

To switch from automatic updating to manual updating of the numeric reading, momentarily press the HOLD key again.

- d. To exit the touch-hold mode, press and hold the HOLD key for two seconds.

Perform the following steps to select the touch-hold mode with manual updating. Display readings in the manual touch-hold mode are changed only when the operator presses the HOLD key.

- a. Set the function selector rotary switch to the OFF position.

- b. Press and hold the HOLD key. Then move the function selector rotary switch to the intended measurement function. Continue to hold the HOLD key down until the completion of the power-on self test.
- c. Momentarily press the HOLD key to enter the touch-hold mode.
- d. Make the intended measurement. The bargraph will respond to changes in the measured value, but the numeric display will not.
- e. To capture the measurement value on the numeric display, momentarily press the HOLD key.
- f. Repeat steps d and e as required.
- g. To exit touch-hold mode, press and hold the HOLD key for two seconds

Section III. OPERATION UNDER UNUSUAL CONDITIONS

2-18. OPERATION IN EXTREME HEAT AND EXTREME COLD.

- . Operate the multimeter only in a temperature range of -15 to +55 degrees Celsius.

2-19. OPERATION IN WET WEATHER.

- . The multimeter will operate normally in a maximum of 95% relative humidity.
- The multimeter has a water resistant (not waterproof) case. The multimeter is not intended to float in water or be submerged.

CHAPTER 3 UNIT MAINTENANCE

	Para	Page
Checking Unpacked Equipment	3-5	3-1
Common Tools and Equipment	3-1	3-1
Disassembly	3-14	3-9
Environment	3-17	3-9
Operational Test	3-8	3-3
Packaging.....	3-15	3-9
Preliminary Servicing and Testing	3-6	3-1
Repair Parts	3-3	3-1
Replace Battery Cover/Holder	3-12	3-7
Replace Install Battery.....	3-9	3-4
Replace Handle/Tilt Stand	3-13	3-8
Replace High Current Range Fuse (F2)	3-10	3-5
Replace mA/μA Range Fuse (F1).....	3-11	3-6
Special Tools, TMDE, and Support Equipment	3-2	3-1
Troubleshooting Table.....	3-7	3-2
Types of Storage	3-16	3-9
Unpacking	3-4	3-1

Section I. REPAIR PARTS, SPECIAL TOOLS, TMDE, AND SUPORT EQUIPMENT

3-1. COMMON TOOLS AND EQUIPMENT.

Common tools and equipment required for unit maintenance of the Digital Multimeter, AN/PSM-45A, are listed in the Maintenance Allocation Chart (MAC) in Appendix B.

3-2. SPECIAL TOOLS, TMDE, AND SUPPORT EQUIPMENT.

There are no special tools, TMDE, or support equipment required.

3-3. REPAIR PARTS.

Repair parts are listed and illustrated in the Repair Parts and Special Tools List, TM 11-6625-3199-24P-1.

Section II. SERVICE UPON RECEIPT

3-4. UNPACKING.

The Digital Multimeter is shipped in its original packing container. Carefully unpack the Digital Multimeter without damaging the shipping carton. Save the carton for use in reshipment.

3-5. CHECKING UNPACKED EQUIPMENT

a. Inspect for damage incurred during shipment. Report any damage on SF 364, Report of Discrepancy (ROD).

b. Check the equipment against the packing slip to see if the shipment is complete. Report all discrepancies in accordance with the instructions of DA PAM 750-8.

c. Check to see whether the equipment has been modified.

3-6. PRELIMINARY SERVICING AND TESTING.

The Digital Multimeter is not shipped with the battery installed. Before attempting to use the Digital Multimeter, install the battery (para 3-9) and perform the operational test (para 3-8).

Section III. TROUBLESHOOTING

SYMPTOM INDEX

Multimeter Symptom	Page
1. Multimeter Not Operating-Display Blank	3-2
2. Multimeter Display Operating But Erratic or No Measurement Functions	3-2
3. No Current Measurement Functions - Other Functions Operate Normally	3-2

3-7. TROUBLESHOOTING TABLE.

Table 3-1 lists common malfunctions that you may find during operation or maintenance of the multimeter. You should perform the tests/ inspections and corrective actions for a particular malfunction in the order given.

NOTE

Table 3-1 does not list all malfunctions that may occur or all tests or inspections and corrective actions. If a malfunction is not listed or is not corrected by listed corrective actions, notify the next higher level of maintenance.

Table 3-1. Troubleshooting

MALFUNCTION	TEST OR INSPECTION	CORRECTIVE ACTION
1. MULTIMETER NOT OPERATING - DISPLAY BLANK.	Check to see if the battery is good.	. Replace battery (para 3-9).
2. MULTIMETER DISPLAY OPERATING BUT ERRATIC OR NO MEASUREMENT FUNCTIONS.	Step 1. Check to see if the test leads/ high voltage probe are defective. Step 2. Check to see if the low battery indicator is on.	. Replace the test leads/ high voltage probe. . Replace the battery (para 3-9).
3. NO CURRENT MEASUREMENT FUNCTIONS-OTHER FUNCTIONS OPERATE NORMALLY.	Step 1. Check to see if the 15A (high current range) fuse (F2) is blown or broken. Step 2. Check to see if the 1A fast (mA/μ A current range) fuse (F1) is blown or broken.	. Replace fuse F2 (para 3-10). . Replace fuse F1 (para 3-11).
4. ANY MALFUNCTIONS NOT COVERED IN (1), (2), or (3).	Contact next higher level of maintenance.	

Section IV. MAINTENANCE PROCEDURES

3-8. OPERATIONAL TEST.

DESCRIPTION

This procedure covers: Operational Readiness Check

1. Connect test leads to the multimeter as follows:

Red lead to the V/ Q/diode test input terminal (1).

Black lead to the COM input terminal (2).

2. Set the function selector rotary switch (3) from OFF to Ω .

3. Watch the display (4) while the multimeter runs the self test. All display segments are switched on for about one second. Verify that all segments are working. After the self test the display should indicate a display overload on the 30 M Ω range.

4. Touch the tips of the test leads (5) together. The display should read the resistance of the test leads, approximately 00.1 ohms.

5. Touch the tip of the red test lead to the A input terminal (6). A display of less than 01.0 ohms verifies that the 15A (high current range) fuse (F2) is good.

6. Touch the tip of the red test lead to the mA/ μ A input terminal (7). A display of less than 10.0 ohms verifies that the 1A (mA/ μ A current range) fuse (F1) is good.

7. Remove the test leads (1 and 2) from the multimeter, and set the function selector rotary switch (3) to OFF.

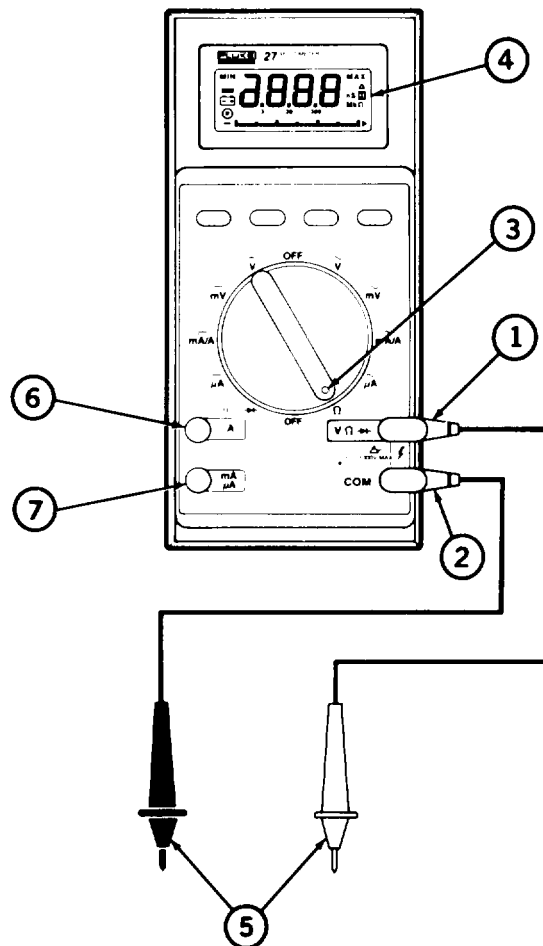

END OF TASK

3-9. REPLACE/INSTALL BATTERY.

DESCRIPTION

This procedure covers: Remove and Install

REMOVE

1. Remove the test leads from the multi meter.
2. Set the function selector rotary switch to OFF.
3. Lift the instrument handle/tilt stand (1) on the back of the multimeter.
4. Remove the four screws (2) from the battery cover/holder (3).
5. Loosen the battery cover/ holder (3) by turning a screwdriver in the coin-slot (4) on the side of the battery cover/holder (3).
6. Lift battery cover/holder (3) straight out of the back of the multimeter.
7. Lift the battery (5) out of the battery cover/holder (3). Then, disconnect the battery connector (6) from the battery (5).

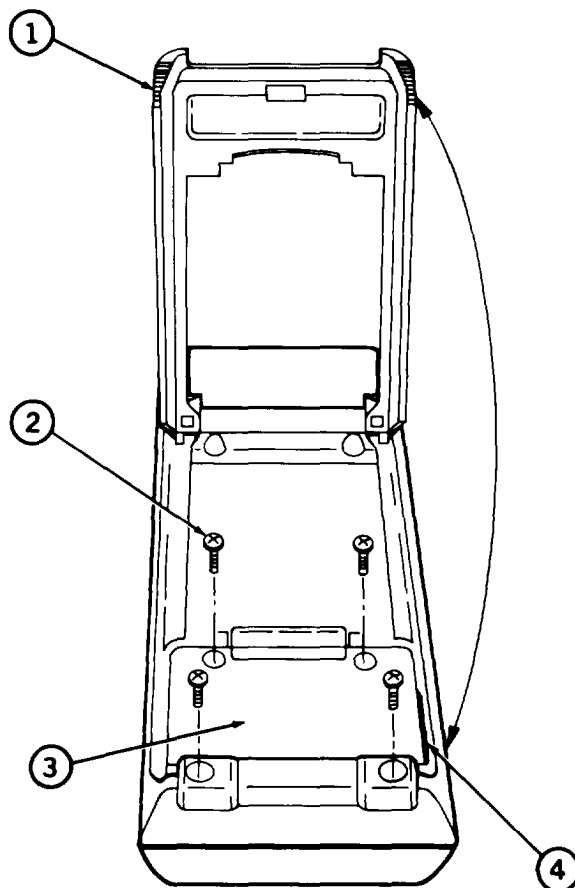

INSTALL

1. Connect the battery connector (6) to the terminals on the replacement battery (5).
2. Slip the battery leads into the slot (7) in the corner of the battery cover/holder (3).
3. Insert the battery (5) into the battery cover/holder (3).
4. Insert the battery cover/holder (3) into the multimeter, and install the four screws (2).

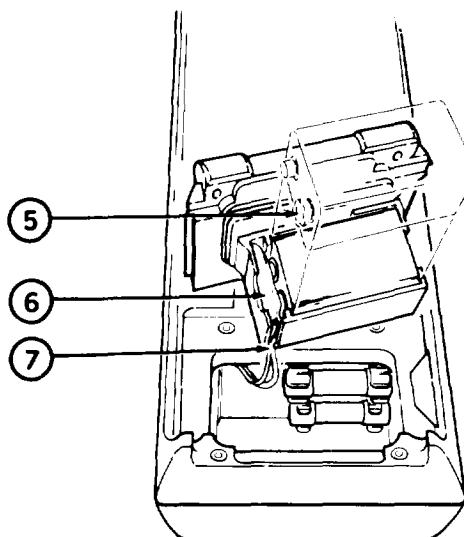

END OF TASK

3-10. REPLACE HIGH CURRENT RANGE FUSE (F2).

DESCRIPTION

This procedure covers: Remove and Install

REMOVE

1. Remove the test leads from the multimeter.
2. Remove the battery cover/holder (1) from the multimeter (para 3-9).
3. Using the tip of a screwdriver, remove fuse F2 (2) from its clip.

INSTALL

1. Replace fuse F2 (2) with a new fuse of the same size and rating (15A, 600V fast blow).
2. Install the battery cover/holder(1) (para 3-9).

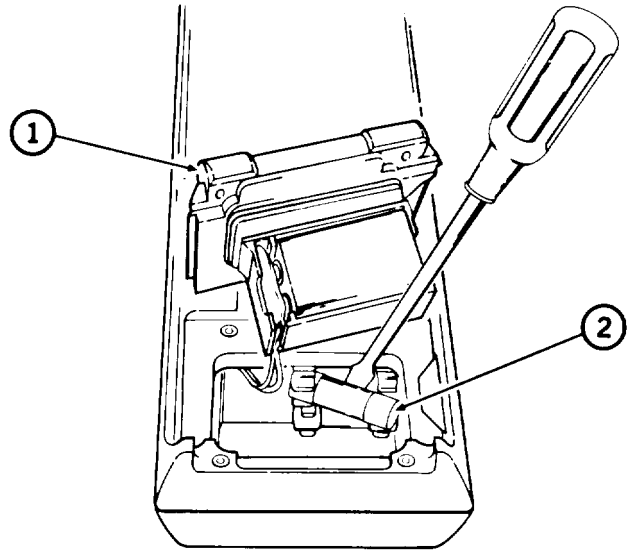
**END OF TASK**

3-11. REPLACE mA/ μ A CURRENT RANGE FUSE(F1).

DESCRIPTION

This procedure covers: Remove and Install

REMOVE

1. Remove the test leads from the multimeter.
2. Remove the battery cover/holder (1) from the multimeter (para 3-9).
3. Using the tip of a screwdriver, remove fuse F1 (2) from its clip.

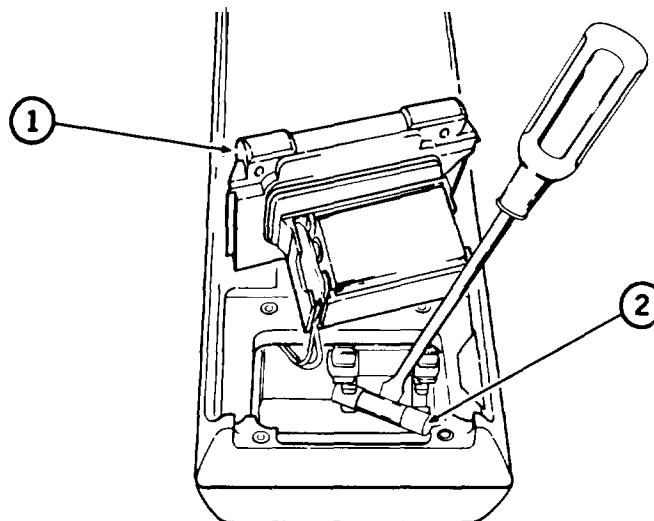

INSTALL

1. Replace fuse F1(2) with a new fuse of the same size and rating (1A, 600V fast blow).
2. Install the battery cover/holder(1) (para 3-9).

END OF TASK

3-12. REPLACE BATTERY COVER/HOLDER.

DESCRIPTION

This procedure covers: Remove and Install

REMOVE

1. Remove the test leads from the multimeter.
2. Remove the battery (1) from the multimeter (para 3-9).
3. Pull the battery terminal wires (2) out of their slot and away from the battery cover/holder.

INSTALL

1. Position the battery terminals (3) inside the battery cover/holder (4).
2. Push the battery terminal wires (2) into the slot in the corner of battery cover.
3. Install the battery (1) and battery cover/ holder (para 3-9).

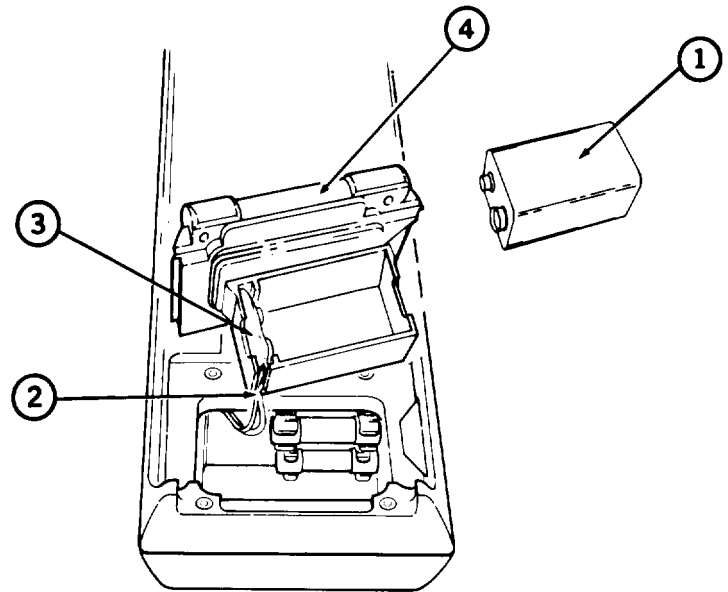

END OF TASK

3-13. REPLACE HANDLE/TILT STAND.

DESCRIPTION

This procedure covers: Remove and Install

REMOVE

1. Remove the test leads from the multimeter.
2. Place the multimeter on its face.
3. Lift the handle; tilt/stand (1) about 1 inch from the back of the multimeter.
4. Pull the hinged ends (2) of the handle) tilt stand away from and out of the multimeter.

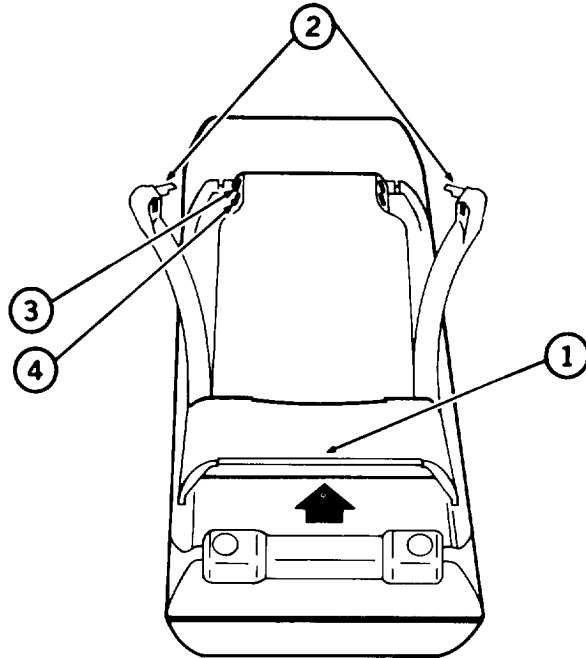

INSTALL

1. Place the multimeter on its face.
2. Position the handle/tilt stand (1) as shown and spread the ends (2) apart.
3. Release the posts on the end of the handle/tilt stand into one set of the hinge holes.

- Use the top set of holes (3) for handle/tilt stand operation.

- . Use the bottom set of holes (4) for carrying handle operation.

END OF TASK

Section V. PREPARATION FOR STORAGE OR SHIPMENT

3-14. DISASSEMBLY.

Perform the following steps to prepare the multimeter for packaging.

- a. Remove the test leads from the input terminals.
- b. Set the function selector rotary switch to OFF.
- c. Remove the battery from the multimeter (para 3-9).

3-15. PACKAGING.

Package the multimeter in the original shipping container. When using packing materials other than the original, use the following guidelines:

- . Wrap the multimeter in plastic packing material.
- . Use a double-wall cardboard shipping container.
- Protect all sides with shock-absorbing material to prevent the multimeter from movement within the container.
- Seal the shipping container with approved sealing tape.
- . Mark "FRAGILE" on all sides, top, and bottom of the shipping container.

3-16. TYPES OF STORAGE.

- . Term (administrative) 1 to 45 days.
- . Intermediate = 46 to 180 days.
- . Long Term = over 180 days. After long-term storage, perform a power-on self test (para 2-4). If the power-on self test fails, notify the next higher level of maintenance.

3-17. ENVIRONMENT.

The multimeter should be stored in a clean, dry environment. In high humidity environments, protect the multimeter from temperature variations that could cause internal condensation. The following environmental conditions apply for both shipping and storage:

Temperature	-55 to +85°C (-67 to +185°F)
Relative humidity	<95% at 0 to 35° C(32 to 95°F)
	<70% at 35 to 55° C (95 to 131° F)

CHAPTER 4 DIRECT SUPPORT MAINTENANCE

There is no direct support maintenance authorized for Digital Multimeter AN/PSM-45A.

CHAPTER 5 GENERAL SUPPORT MAINTENANCE

	Para	Page
Calibration	5 - 5	5-1
Common Tools and Equipment	5-1	5-1
Performance Tests	5-6	5-1
Repair Parts	5-3	5-1
Special Tools, TMDE, and Support Equipment	5-2	5-1
Troubleshooting	5-4	5-1

Section I. REPAIR PARTS, SPECIAL TOOLS, TMDE, AND SUPPORT EQUIPMENT

5-1. COMMON TOOLS AND EQUIPMENT.

Common tools and equipment required for general support maintenance of Digital Multimeter AN/PSM-45A are listed in the Maintenance Allocation Chart (MAC) in Appendix B.

5-2. SPECIAL TOOLS, TMDE, AND SUPPORT EQUIPMENT.

There are no special tools, TMDE, or support equipment required.

5-3. REPAIR PARTS.

There are no repair parts authorized.

Section II. TROUBLESHOOTING

5-4. TROUBLESHOOTING.

No general support troubleshooting is authorized or required. Upon failure, return the entire contents of the end item to unit level for disposal.

Section III. MAINTENANCE PROCEDURES

5-5. CALIBRATION.

Calibration is performed in accordance with the technical bulletin listed in TB 43-180. Upon failure of any calibration procedure, return the entire contents of the end item to unit level for disposal.

5-6. PERFORMANCE TESTS.

After satisfactory calibration, compare the multimer performance with the equipment data in paragraph 1-11. If the multimeter fails to meet any listed specification, return the entire contents of the end item to unit level for disposal.

APPENDIX A REFERENCES

A-1. SCOPE.

This appendix lists all forms, field manuals, technical manuals, and miscellaneous publication references in this manual.

A-2. FORMS.

Product Quality Deficiency Report.....	Form SF 368
Recommended Changes to Publications and Blank Forms	DA Form 2028
Report of Discrepancy (ROD).....	Form SF 364
Transportation Discrepancy Report (TDR)	Form SF 361

A-3. TECHNICAL MANUALS.

Unit, Intermediate Direct Support, and General Support Maintenance Manual Repair Parts and Special Tools Lists for Digital, AN/PSM-45A, (NSN 6625-01-265-6000)	TM 11-6625-3199-24P-1
Procedures for Destruction of Electronics Materiel to Prevent Enemy Use (Electronics Command)	TM 750-244-2

A-4. MISCELLANEOUS PUBLICATIONS.

The American Society of Mechanical Engineers, Abbreviations and Acronyms	ASME Y14.38
Common Table of Allowance, Expendable/Durable Items (Except Medical, Class V, Repair Parts, and Heraldic Items)	CTA 50-970
Consolidated Army Publications and Forms Index.....	DA PAM 25-30
First Aid.....	FM 4-25.11
Reporting of Supply Discrepancies.....	AR 735-11-2
Interactive Electronic Technical Manual (IETM) for Calibration and Repair Requirements for the Maintenance of Army Materiel	TB 43-180
Safety Requirements for Maintenance of Electrical and Electronic Equipment.....	TB 385-4
The Army Maintenance Management System (TAMMS) Users Manual.....	DA PAM 750-8

APPENDIX B MAINTENANCE ALLOCATION CHART (MAC)

SECTION I. INTRODUCTION

B-1. GENERAL.

a. This introduction provides a general explanation of all maintenance and repair function authorized at the two maintenance levels under the Two-Level Maintenance System concept.

b. The MAC in Section II designates overall authority and responsibility for the performance of maintenance functions on the identified end-item or component. The application of the maintenance functions to the end-item or component shall be consistent with the capabilities of the designated maintenance levels, which are shown on the MAC in Column (4) as:

1. Field – includes two sub-columns, Unit (C (operator/crew) and O (unit) maintenance) and Direct Support (F) maintenance.
2. Sustainment – includes two sub-columns, general support (H) and depot (D).

c. The tools and test equipment requirements in Section III list the tools and test equipment (both special tools and common tool sets) required for each maintenance function as referenced from the MAC.

d. The remarks in Section IV contain supplemental instructions and explanatory notes for a particular maintenance function.

B-2. MAINTENANCE FUNCTIONS.

Maintenance functions are limited to and defined as follows:

a. **Inspect.** To determine the serviceability of an item by comparing its physical, mechanical, and/or electrical characteristics with established standards through examination (e.g. by sight, sound, or feel). This includes scheduled inspection and gagings and evaluation of cannon tubes.

b. **Test.** To verify serviceability by measuring the mechanical, pneumatic, hydraulic, or electrical characteristics of an item and comparing those characteristics with prescribed standards on a scheduled basis, i.e., load testing of lift devices and hydrostatic testing of pressure hoses.

c. **Service.** Operations required periodically to keep an item in proper operating condition; e.g., to clean (includes decontaminate, when required), to preserve, to drain, to paint, or to replenish fuel, lubricants, chemical fluids, or gases. This includes scheduled exercising and purging of recoil mechanisms.

d. **Adjust.** To maintain or regulate, within prescribed limits, by bringing into proper position, or by setting the operating characteristics to specified parameters.

e. **Align.** To adjust specified variable elements of an item to bring about optimum or desired performance.

f. Calibrate. To determine and cause corrections to be made or to be adjusted on instruments of test, measuring, and diagnostic equipment used in precision measurement. This consists of comparisons of two instruments, one of which is a certified standard of known accuracy, to detect and adjust any discrepancy in the accuracy of the instrument being compared.

g. Remove/Install. To remove and install the same item when required to perform service or other maintenance functions. Install may be the act of emplacing, seating, or fixing into position a spare, repair part, or module (component or assembly) in a manner to allow the proper functioning of an equipment or system.

h. Replace. To remove an unserviceable item and install a serviceable counterpart in its place "Replace" is authorized by the MAC and an assigned maintenance level is shown as the third position code of the Source, Maintenance and Recoverability (SMR) code.

i. Repair. The application of maintenance services, including fault location/troubleshooting, removal/installation, disassembly/assembly procedures and maintenance actions to identify troubles and restore serviceability to an item by correcting specific damage, fault, malfunction, or failure in a part, subassembly, module (component or assembly), end-item or system.

NOTE

The following definitions are applicable to the "repair" maintenance function:

1. Services. Inspect, test, service adjust, align, calibrate, and/or replace.
2. Fault location/troubleshooting. The process of investigating and detecting the cause of equipment malfunctioning; the act of isolating a fault within a system or Unit Under Test (UUT).
3. Disassembly/assembly. The step-by-step breakdown (taking apart) of a spare/functional group coded item to the level of its least component, that is assigned an SMR code for the level of maintenance under consideration (i.e., identified as maintenance significant).
4. Actions. Welding, grinding, riveting, straightening, facing, machining, and/or resurfacing.

j. Overhaul. That maintenance effort (service/action) prescribed to restore an item to a completely serviceable/operational condition as required by maintenance standards described in appropriate technical publications. Overhaul is normally the highest degree of maintenance performed by the Army. Overhaul does not normally return an item to like-new condition.

k. Rebuild. Consists of those services/actions necessary for the restoration of unserviceable equipment to a like-new condition in accordance with original manufacturing standards. Rebuild is the highest degree of material maintenance applied to Army equipment. The rebuild operation includes the act of returning to zero those age measurements (e.g., hours/miles) considered in classifying Army equipment/components.

B-3. EXPLANATION OF COLUMNS IN THE MAC, SECTION II.

a. Column (1) Group Number. Column (1) lists Functional Group Code (FGC) numbers, the purpose of which is to identify maintenance significant components, assemblies, subassemblies, and modules with the Next Higher Assembly (NHA).

b. Column (2) Component/Assembly. Column (2) contains the item names of components, assemblies, subassemblies, and modules for which maintenance is authorized.

c. Column (3) Maintenance Function. Column (3) lists the functions to be performed on the item listed in Column (2). (For a detailed explanation of these functions, refer to "Maintenance Functions" outlined above.)

d. Column (4) Maintenance Level. Column (4) specifies each level of maintenance authorized to perform each function listed in Column (3), by indicating work-time required (expressed as man-hours in whole hours or decimals) in the appropriate sub-column. The work-time figure represents the active time required to perform that maintenance function at the indicated level of maintenance. If the number or complexity of the tasks within the listed maintenance function varies at different maintenance levels, appropriate work-time figures are to be shown for each level. The work-time figure represents the average time required to restore an item (assembly, subassembly, component, module, end-item or system) to a serviceable condition under typical field operating conditions. This time includes preparation time (including any necessary disassembly/assembly time), troubleshooting/fault location time, and quality assurance time in addition to the time required to perform the specific tasks identified for the maintenance functions authorized in the MAC. The symbol designations for the various maintenance levels are as follows:

1. Field:
 - C Operator or Crew maintenance
 - O Unit maintenance
 - F Direct Support maintenance
2. Sustainment:
 - H General Support maintenance
 - D Depot maintenance

NOTE

The "L" maintenance level is not included in Column (4) of the MAC. Functions to this level of maintenance are identified by a work-time figure in the "H" column of Column (4), and an associated reference code is used in the REMARKS CODE Column, Column (6). This code is keyed to the remarks, and the Specialized Repair Activity (SRA) complete repair application is explained there.

e. Column (5) Tools and Equipment Reference Code. Column (5) specifies, by code, those common tool sets (not individual tools), common Test, Measurement and Diagnostic Equipment (TMDE), and special tools, special TMDE and special support equipment required to perform the designated function. Codes are keyed to the entries in the tools and test equipment table.

f. Column (6) Remarks Code. When applicable, this column contains a letter code, in alphabetical order, which is keyed to the remarks table entries.

B-4. EXPLANATION OF COLUMNS IN TOOLS AND TEST EQUIPMENT REQUIREMENTS, SECTION III.

a. Column (1) Tool or Test Equipment Reference Code. The tool or test equipment reference code correlates with a code used in Column (5) of the MAC.

b. Column (2) Maintenance Level. The lowest level of maintenance authorized to use the tool or test equipment.

c. Column (3) Nomenclature. Name or identification of the tool or test equipment.

- d. **Column (4) National Stock Number (NSN).** The NSN of the tool or test equipment.
- e. **Column (5) Tool Number.** The manufacturer's part number, model number, or type number.

B-5. EXPLANATION OF COLUMNS IN THE REMARKS, SECTION IV.

- a. **Column (1) Remarks Code.** The code recorded in Column (6) of the MAC.
- b. **Column (2) Remarks.** This column lists information pertinent to the maintenance function being performed as indicated in the MAC.

**SECTION II. MAINTENANCE ALLOCATION CHART (MAC)
FOR
DIGITAL MULTIMETER, AN/PSM-45A**

TABLE 1. MAC FOR DIGITAL MULTIMETER, AN/PSM-45A

(1) GROUP NUMBER	(2) COMPONENT/ ASSEMBLY	(3) MAINTENANCE FUNCTION	(4) MAINTENANCE LEVEL					(5) TOOLS AND EQUIPMENT REFERENCE CODE	(6) REMARKS CODE
			FIELD			SUSTAINMENT			
			UNIT		DS	GS	DEPOT		
			C	O	F	H	D		
00	DIGITAL MULTIMETER AN/PSM-45A	INSPECT INSPECT REPAIR		0.1 0.1	0.1			A A B	
01	MULTIMETER	INSPECT TEST REPAIR CALIBRATE REPAIR		0.1 0.1 0.1	0.8 0.1		1.2 2-5	A C D E F	

**SECTION III. TOOLS AND TEST EQUIPMENT REQUIREMENTS
FOR
DIGITAL MULTIMETER, AN/PSM-45A**

**TABLE 2. TOOLS AND TEST EQUIPMENT REQUIREMENTS FOR DIGITAL MULTIMETER
AN/PSM-45A**

(1) TOOLS/TEST EQUIPMENT REFERENCE CODE	(2) MAINTENANCE LEVEL	(3) NOMENCLATURE	(4) NATIONAL STOCK NUMBER	(5) TOOL NUMBER
1	O	Screwdriver, Cross Tip	5120-01-113-7149	SSDZ42
2	O	Tool Kit, Electronic	5180-00-064-5178	TK-101/G
3	F	Tool Kit, Electrician's	4931-01-073-3845	JTK-17LAL
4	F	Test Set, Electrical	6625-00-935-7002	Fluke 760A
5	F	Calibrator, Multifunction	6625-01-481-2461	5700 A/EP

SECTION IV. REMARKS FOR DIGITAL MULTIMETER, AN/PSM-45A

TABLE 3. REMARKS FOR DIGITAL MULTIMETER, AN/PSM-45A

REMARKS CODE	REMARKS
A	Visual inspection.
B	Repair is limited to replacement of test leads, high voltage probe, and carrying case.
C	Operational test.
D	Repair is limited to fuses (F1, F2), battery, and ball.
E	Perform calibration using technical bulletin listed in TB 43-180.
F	Repair is limited to calibration of the meter. Upon failure of calibration, return the end-item to unit level for disposal.

APPENDIX C

COMPONENTS OF END ITEM AND BASIC ISSUE ITEMS LIST

Section 1. INTRODUCTION

C-1. SCOPE.

This appendix lists components of the end item and basic issue items for the Digital Multimeter to help you inventory items required for safe and efficient operation.

C-2. GENERAL.

The components of End Item and Basic Issue Items List (BII) are divided into the following sections:

a. *Section II—Components of End Item* This listing is for information purposes only and is not authority to requisition replacements. These are part of the end item, but are removed and/or separately packaged for transportation or shipment. As part of the end item, these items must be with the end item whenever it is issued or transferred between property accounts. Illustrations are furnished to assist you in identifying the items.

b. *Section 111—Basic Issue Items* These are the minimum essential items required to place the Digital Multimeter in operation, to operate it, and to perform emergency repairs. Although shipped separately packaged, BII must be with the Digital Multimeter during operation and whenever it is transferred between property accounts. This manual is your authority to request/requisition replacement BII, based on TOE/MTOE authorization of the end item.

C-3. EXPLANATION OF COLUMNS.

a. *Column (1) Illustration Number (Illus Number).* This column indicates the number of the illustration in which the item is shown.

b. *Column (2) National Stock Number.* This column indicates the national stock number assigned to the item and will be used for requisitioning purposes,

c. *Column (3) Description.* This column indicates the federal item name and, if required, a minimum description to identify and locate the item. The last line for each item indicates the FSCM (in parentheses) followed by the part number.

d. *Column (4)— Unit of Measure (U/M).* This column indicates the measure used in performing the actual operation, maintenance function. This measure is expressed by a two-character alphabetical abbreviation (e. g., ea, in, pr).

e. *Column (5)— Quantity Required (Qty Rqr).* This column indicates the quantity of the item authorized to be used with/on the equipment.

Section II. COMPONENTS OF END ITEM

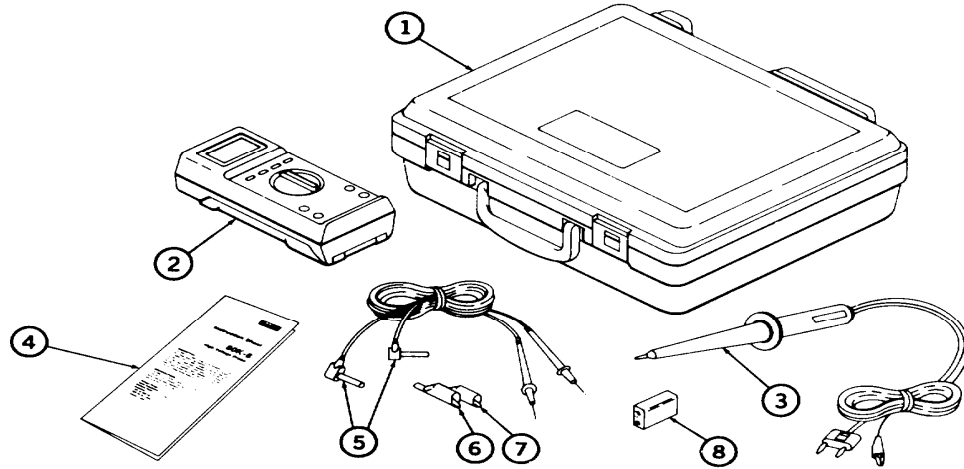

(1) ILLUS NUMBER	(2) NATIONAL STOCK NUMBER	(3) DESCRIPTION CAGEC AND PART NUMBER	(4) U/M	(5) QTY RQR
1		Carrying Case (89536) 821736	ea	1
2		Multimeter (89536)	ea	1
3	6625-01-147-0112	High Voltage Probe (89536) Model No. 80K-6	ea	1
4		Instruction Sheet (89536) 613224	ea	1
5	6625-01-220-5608	Lead, Test (89536) TL71	ea	1
6	5999-01-204-7257	Clip, Electrical Alligator, Red (89536) AC70-4201-01	ea	1
7	5999-01-204-4904	Clip, Electrical Needle Clip, Black (89536) AC70-4201	ea	1
8	6135-00-900-2139	Battery, Non-Rechargeable, 9V (80058) BA-3090/U	ea	1

APPENDIX D ADDITIONAL AUTHORIZATION LIST

SECTION I. INTRODUCTION

D-1. SCOPE.

This appendix lists additional items you are authorized for the support of the Digital Multimeter.

D-2. GENERAL.

This identifies items that do not have to accompany the Digital Multimeter and that do not have to be turned in with it. The items are all authorized to you by CTA, MTOE, TDA, or JTA.

D-3. EXPLANATION OF LISTING.

National Stock Numbers, descriptions, and quantities are provided to help you identify and request the additional items you require to support this equipment. The items are listed in alphabetical sequence by item name under the type document (i.e., CTA, MTOE, TD, or JTA) which authorized the item(s) to you.

Section II. ADDITIONAL AUTHORIZATION LIST

(1) NATIONAL STOCK NUMBER	(2) DESCRIPTION CAGE AND PART NUMBER USABLE ON CODE	(3) U/M	(4) QTY AUTH
5920-00-615-3781	Fuse 2A, 600V (71400) BBS1	ea	1
5920-01-103-4526	Fuse 2A, 600V (71400) KTK-R-15	ea	1
6135-00-900-2139	Battery, Non-Rechargeable 9V (80058) BA-3090/U	ea	1

APPENDIX E EXPENDABLE SUPPLIES AND MATERIALS LIST

SECTION I. INTRODUCTION

E-1. SCOPE.

This appendix lists expendable supplies and materials you will need to maintain the test set. These items are authorized to you by CTA 50-970, Expendable/Durable Items (Except Medical, Class V, Repair Parts, and Heraldic Items).

E-2. EXPLANATION OF COLUMNS.

a. Column (1) - Item Number. This number is assigned to the entry in the listing and is referenced in the narrative instructions to identify the material e.g., (Use cleaning compound, item 5, App. E”).

b. Column (2) - Level. This column identifies the lowest level of maintenance that requires the listed item.

C - Operator/Crew

c. Column (3) - National Stock Number. This is the National stock number assigned to the item and will be used for requisitioning purposes.

d. Column (4) - Description. This column indicates the federal item name and, if required, a description to identify the item. The last line for each item indicates the Commercial and Government Entity Code (CAGEC) (in parentheses) followed by the part number.

e. Column (5) - Unit of Measure (U/M). This column indicates the measure used in performing the actual maintenance function. This measure is expressed by a two-character alphabetical abbreviation (e.g., ea, in, pr). If the unit of measure differs from the unit of issue, requisition the lowest unit of issue that will satisfy your requirements.

Section II. EXPENDABLE SUPPLIES AND MATERIALS LIST

(1) ITEM NUMBER	(2) LEVEL	(3) NATIONAL STOCK NUMBER	(4) DESCRIPTION	(5) U/M
1	C	8305-00-267-3015	Cloth, Cheesecloth, Cotton Lintless, CCC-C-440, Type II Class 2 (81348)	yd
2	C		Detergent, Mild, Liquid	ea

INDEX

Subject	Paragraph Figure, Table Number
A	
Abbreviations	1-9
AC Current Measurements.....	2-9
AC Voltage Measurements	2-6
Additional Authorization List	Appendix D
Administrative Storage	1-4
B	
Battery Replacement	3-9
C	
Calibration	5-5
Components of End Item	Appendix C
Conductance Measurements	2-11
Consolidated Index of Army Publications and Blank Forms	1-2
Continuity Measurements	2-12
Controls, indicators, and Connectors	2-1
D	
DC Current Measurements	2-8
DC Voltage Measurements	2-5
Description of Controls	2-1
Destruction of Army Electronics Materiel	1-5
Diode Test	2-13
Disassembly	3-14
E	
Environment	3-17
Equipment Characteristics, Capabilities and Features	1-10
Equipment Data	1-11
Equipment Improvement Recommendations	1-6
Expendable Supplies and Materials List	Appendix E
F	
Functional Description	1-12
Fuse Replacement	3-10,3-11

INDEX-Continued

G

General Functional Description 1-12

H

Handle/Tilt Stand Replacement 3-13
 High Voltage Measurements 2-7
 High Current Range Fuse... 3-10
 Humidity 1-11

I

Indicators 2-1
 Input Characteristics 1-11

L

List of Abbreviations 1-9
 List of Additional Authorization Appendix D
 List of Capabilities 1-10
 List of Characteristics 1-10
 List of Common Names 1-8
 List of Components of End Item Appendix C
 List of Equipment Data..., 1-11
 List of Expendable Supplies and Materials Appendix E
 List of Features....., 1-10
 List of References Appendix A

M

Maintenance Forms, Records, and Reports 1-3
 Manual Range Mode 2-14
 Min/Max Mode 2-16
 Maintenance Allocation Chart (MAC) Appendix B

N

Nomenclature Cross-Reference List 1-8

O

Operating Procedures 2-4
 Operating Temperature Range 1-11
 Operation in Extreme Heat and Extreme Cold 2-18
 Operation in Wet Weather 2-19
 Operational Test 3-8
 Operator's Controls, indicators, and Connectors 2-1

INDEX-Continued

P

Packaging	3-15
Parts, Repair	3-3
Performance Characteristics	1-11
Performance Tests	5-6
Power-On Self Test	2-3
Power Requirements	1-11
Preliminary Servicing and Testing	3-6

R

Range Mode, Manual	2-14
Range, Operating Temperature	1-11
Records and Reports, Maintenance	1-3
References	Appendix A
Relative Humidity	1-11
Relative Mode	2-15
Relative Value Annunciator	2-1
Repair Parts	3-3
Replace/Install Battery	3-9
Replace Battery Cover/Holder	3-12
Replace Fuses	3-10,3-11
Replace Handle/Tilt Stand	3-13
Resistance Annunciators	2-1
Resistance Measurements	2-10

S

Servicing, Preliminary	3-6
Special Tools and Support Equipment	3-2
Storage	3-16
Storage Temperature Range	3-17

T

Temperature, Operating	1-11
Touch-Hold Measurements	2-17
Troubleshooting Table	3-7
Type of Manual	1-1
Types of Storage	3-16
Tools and Test Equipment	Appendix B

INDEX-Continued

U

Unpacking 3-4

V

Voltage Measurements, AC 2-6

Voltage Measurements, DC 2-5

Voltage Measurements, High 2-7

W

Warnings A,B

Warranty 1-7

Weight 1-11

By Order of the Secretary of the Army:

Official:

CARL E. VUONO
General, United States Army
Chief of Staff

R. L. DILWORTH
Brigadier General, United States Army
The Adjutant General

Distribution:

To be distributed in accordance with special list.

These are the instructions for sending an electronic 2028

The following format must be used if submitting an electronic 2028. The subject line must be exactly the same and all fields must be included; however only the following fields are mandatory: 1, 3, 4, 5, 6, 7, 8, 9, 10, 13, 15, 16, 17, and 27.

From: "Whomever" <whomever@wherever.army.mil>

To: 2028@redstone.army.mil

Subject: DA Form 2028

- 1. From: Joe Smith**
- 2. Unit: home**
- 3. Address: 4300 Park**
- 4. City: Hometown**
- 5. St: MO**
- 6. Zip: 77777**
- 7. Date Sent: 19-OCT-93**
- 8. Pub no: 55-2840-229-23**
- 9. Pub Title: TM**
- 10. Publication Date: 04-JUL-85**
- 11. Change Number: 7**
- 12. Submitter Rank: MSG**
- 13. Submitter FName: Joe**
- 14. Submitter MName: T**
- 15. Submitter LName: Smith**
- 16. Submitter Phone: 123-123-1234**
- 17. Problem: 1**
- 18. Page: 2**
- 19. Paragraph: 3**
- 20. Line: 4**
- 21. NSN: 5**
- 22. Reference: 6**
- 23. Figure: 7**
- 24. Table: 8**
- 25. Item: 9**
- 26. Total: 123**
- 27. Text:**

This is the text for the problem below line 27.

RECOMMENDED CHANGES TO PUBLICATIONS AND BLANK FORMS <small>For use of this form, see AR 25-30; the proponent agency is ODISC4.</small>						Use Part II (reverse) for Repair Parts and Special Tool Lists (RPSTL) and Supply Catalogs/Supply Manuals (SC/SM)	DATE 8/30/02
TO: (Forward to proponent of publication or form)(Include ZIP Code) Commander, U.S. Army Aviation and Missile Command ATTN: AMSAM-MMC-MA-NP Redstone Arsenal, 35898						FROM: (Activity and location)(Include ZIP Code) MSG, Jane Q. Doe 1234 Any Street Nowhere Town, AL 34565	
PART 1 - ALL PUBLICATIONS (EXCEPT RPSTL AND SC/SM) AND BLANK FORMS							
PUBLICATION/FORM NUMBER TM 9-1005-433-24						DATE 16 Sep 2002	TITLE Organizational, Direct Support, And General Support Maintenance Manual for Machine Gun, .50 Caliber M3P and M3P Machine Gun Electrical Test Set Used On Avenger Air Defense Weapon System
ITEM NO.	PAGE NO.	PARA-GRAPH	LINE NO. *	FIGURE NO.	TABLE NO.	RECOMMENDED CHANGES AND REASON	
1	WP0005 PG 3		2			Test or Corrective Action column should identify a different WP number.	
EXAMPLE							
<small>* Reference to line numbers within the paragraph or subparagraph.</small>							
TYPED NAME, GRADE OR TITLE MSG, Jane Q. Doe, SFC				TELEPHONE EXCHANGE/ AUTOVON, PLUS EXTENSION 788-1234		SIGNATURE	

TO: (Forward direct to addressee listed in publication) Commander, U.S. Army Aviation and Missile Command ATTN: AMSAM-MMC-MA-NP Redstone Arsenal, 35898	FROM: (Activity and location) (Include ZIP Code) MSG, Jane Q. Doe 1234 Any Street Nowhere Town, AL 34565	DATE 8/30/02
---	--	------------------------

PART II - REPAIR PARTS AND SPECIAL TOOL LISTS AND SUPPLY CATALOGS/SUPPLY MANUALS

PUBLICATION NUMBER			DATE	TITLE				
PAGE NO.	COLM NO.	LINE NO.	NATIONAL STOCK NUMBER	REFERENCE NO.	FIGURE NO.	ITEM NO.	TOTAL NO. OF MAJOR ITEMS SUPPORTED	RECOMMENDED ACTION

PART III - REMARKS (Any general remarks, corrections, or suggestions for improvement of publications and blank forms. Additional blank sheets may be used if more space is needed.)

EXAMPLE

TYPED NAME, GRADE OR TITLE MSG, Jane Q. Doe, SFC	TELEPHONE EXCHANGE/AUTOVON, PLUS EXTENSION 788-1234	SIGNATURE
---	--	-----------

RECOMMENDED CHANGES TO PUBLICATIONS AND BLANK FORMS <small>For use of this form, see AR 25-30; the proponent agency is ODISC4.</small>						Use Part II (<i>reverse</i>) for Repair Parts and Special Tool Lists (RPSTL) and Supply Catalogs/Supply Manuals (SC/SM)	DATE
TO: (<i>Forward to proponent of publication or form</i>)(<i>Include ZIP Code</i>)						FROM: (<i>Activity and location</i>)(<i>Include ZIP Code</i>)	
PART 1 - ALL PUBLICATIONS (EXCEPT RPSTL AND SC/SM) AND BLANK FORMS							
PUBLICATION/FORM NUMBER						DATE	TITLE
ITEM NO.	PAGE NO.	PARA-GRAPH	LINE NO. *	FIGURE NO.	TABLE NO.	RECOMMENDED CHANGES AND REASON	
<small>* Reference to line numbers within the paragraph or subparagraph.</small>							
TYPED NAME, GRADE OR TITLE						TELEPHONE EXCHANGE/ AUTOVON, PLUS EXTENSION	SIGNATURE

TO: (Forward direct to addressee listed in publication)	FROM: (Activity and location) (Include ZIP Code)	DATE
--	---	-------------

PART II - REPAIR PARTS AND SPECIAL TOOL LISTS AND SUPPLY CATALOGS/SUPPLY MANUALS

PUBLICATION NUMBER	DATE	TITLE
--------------------	------	-------

PAGE NO.	COLM NO.	LINE NO.	NATIONAL STOCK NUMBER	REFERENCE NO.	FIGURE NO.	ITEM NO.	TOTAL NO. OF MAJOR ITEMS SUPPORTED	RECOMMENDED ACTION

PART III - REMARKS (Any general remarks or recommendations, or suggestions for improvement of publications and blank forms. Additional blank sheets may be used if more space is needed.)

TYPED NAME, GRADE OR TITLE	TELEPHONE EXCHANGE/AUTOVON, PLUS EXTENSION	SIGNATURE
----------------------------	--	-----------

RECOMMENDED CHANGES TO PUBLICATIONS AND BLANK FORMS <small>For use of this form, see AR 25-30; the proponent agency is ODISC4.</small>						Use Part II (reverse) for Repair Parts and Special Tool Lists (RPSTL) and Supply Catalogs/Supply Manuals (SC/SM)	DATE
TO: (Forward to proponent of publication or form)(Include ZIP Code)						FROM: (Activity and location)(Include ZIP Code)	
PART 1 - ALL PUBLICATIONS (EXCEPT RPSTL AND SC/SM) AND BLANK FORMS							
PUBLICATION/FORM NUMBER						DATE	TITLE
ITEM NO.	PAGE NO.	PARA-GRAPH	LINE NO. *	FIGURE NO.	TABLE NO.	RECOMMENDED CHANGES AND REASON	
<i>* Reference to line numbers within the paragraph or subparagraph.</i>							
TYPED NAME, GRADE OR TITLE						TELEPHONE EXCHANGE/ AUTOVON, PLUS EXTENSION	SIGNATURE

TO: (Forward direct to addressee listed in publication)	FROM: (Activity and location) (Include ZIP Code)	DATE
--	---	-------------

PART II - REPAIR PARTS AND SPECIAL TOOL LISTS AND SUPPLY CATALOGS/SUPPLY MANUALS

PUBLICATION NUMBER	DATE	TITLE
---------------------------	-------------	--------------

PAGE NO.	COLM NO.	LINE NO.	NATIONAL STOCK NUMBER	REFERENCE NO.	FIGURE NO.	ITEM NO.	TOTAL NO. OF MAJOR ITEMS SUPPORTED	RECOMMENDED ACTION

PART III - REMARKS (Any general remarks or recommendations, or suggestions for improvement of publications and blank forms. Additional blank sheets may be used if more space is needed.)

TYPED NAME, GRADE OR TITLE	TELEPHONE EXCHANGE/AUTOVON, PLUS EXTENSION	SIGNATURE
----------------------------	--	-----------

RECOMMENDED CHANGES TO PUBLICATIONS AND BLANK FORMS <small>For use of this form, see AR 25-30; the proponent agency is ODISC4.</small>						Use Part II (reverse) for Repair Parts and Special Tool Lists (RPSTL) and Supply Catalogs/Supply Manuals (SC/SM)	DATE
TO: (Forward to proponent of publication or form)(Include ZIP Code)						FROM: (Activity and location)(Include ZIP Code)	
PART 1 - ALL PUBLICATIONS (EXCEPT RPSTL AND SC/SM) AND BLANK FORMS							
PUBLICATION/FORM NUMBER						DATE	TITLE
ITEM NO.	PAGE NO.	PARA-GRAPH	LINE NO. *	FIGURE NO.	TABLE NO.	RECOMMENDED CHANGES AND REASON	
<i>* Reference to line numbers within the paragraph or subparagraph.</i>							
TYPED NAME, GRADE OR TITLE						TELEPHONE EXCHANGE/ AUTOVON, PLUS EXTENSION	SIGNATURE

TO: (Forward direct to addressee listed in publication)	FROM: (Activity and location) (Include ZIP Code)	DATE
--	---	-------------

PART II - REPAIR PARTS AND SPECIAL TOOL LISTS AND SUPPLY CATALOGS/SUPPLY MANUALS

PUBLICATION NUMBER	DATE	TITLE
---------------------------	-------------	--------------

PAGE NO.	COLM NO.	LINE NO.	NATIONAL STOCK NUMBER	REFERENCE NO.	FIGURE NO.	ITEM NO.	TOTAL NO. OF MAJOR ITEMS SUPPORTED	RECOMMENDED ACTION

PART III - REMARKS (Any general remarks or recommendations, or suggestions for improvement of publications and blank forms. Additional blank sheets may be used if more space is needed.)

TYPED NAME, GRADE OR TITLE	TELEPHONE EXCHANGE/AUTOVON, PLUS EXTENSION	SIGNATURE
----------------------------	--	-----------

